

THE B.A.S. SPEAKER

EDITOR-IN-CHIEF: Brad Meyer

STAFF: Robert Borden, Frank Farlow, Scott Kent,
John Schlafer, Jack Stevens

PUBLISHER: Peter W. Mitchell, President, BAS

Subscriptions & Membership Information

THE BOSTON AUDIO SOCIETY
P.O. BOX 7
BOSTON, MASSACHUSETTS 02215

VOLUME 8, NUMBER 5
FEBRUARY 1980

THE BOSTON AUDIO SOCIETY DOES NOT ENDORSE OR CRITICIZE PRODUCTS, DEALERS, OR SERVICES. OPINIONS EXPRESSED HEREIN REFLECT THE VIEWS OF THEIR AUTHORS AND ARE FOR THE INFORMATION OF THE MEMBERS. REPRODUCTION OF ANY PORTION OF THIS NEWSLETTER FOR ANY PURPOSE WHATSOEVER WITHOUT WRITTEN PERMISSION OF THE PUBLISHER IS STRICTLY PROHIBITED.

In This Issue

Most of the magazine is taken up this time by two items. The first is the meeting report of Bob Carver's most recent visit to the BAS, in which he described for the first time the principles of operation of the Carver M-400 magnetic field power amplifier. This device is not really a magnetic amplifier in the previously understood sense of the term, but rather an extremely clever combination of several innovations, one of which involves the temporary storage of energy in the magnetic field around the power transformer. The way it all works together seems so simple after you understand it that many people in the audience were left wondering why it hadn't been thought of before.

The other big article is the second half of the turntable/arm/cartridge test report, including a detailed discussion of why the conventional ways of specifying turntable performance are misleading and/or inaccurate. Descriptions and results of tests for horizontal arm/cartridge resonance, rumble, and resistance to acoustic and mechanical feedback are given, as well as the numerical results of the flutter tests described last month.

There is a smattering of other goodies as well, of course. One is a rather depressing report on the quality of FM broadcasting in the Washington, D. C. area. There is a reply from Ball Corporation concerning record degreasing which you should read if you have been tempted to try and remove Sound Guard from a disc. And more.

The U. S. Post Office is starting to get testy about the scheduling of the Speaker. This means that lack of material can no longer be an excuse to delay publication. You can help keep this magazine from wasting away by sending us the reports, comments, etc. that you have been thinking of writing. Spring is here. Take a break from whatever you've been doing all winter and write us something nice.

-- Brad Meyer

The B.A.S. Speaker (ISSN 0195-0908) is published monthly by The Boston Audio Society, Trapelo Road, Lincoln, MA 01773. Subscriptions are available to members of the Society. Membership dues are \$12 per year, October 1 through September 30 (\$25 U.S. currency overseas, including air mail). \$11.45 of the dues are a subscription to *The B.A.S. Speaker* including all issues of the applicable membership year. **For further information and application form, write to The Boston Audio Society, P.O. Box 7, Kenmore Square Station, Boston, MA 02215.** Second-class postage paid at Boston, MA. POSTMASTER: Send address changes to: The B.A.S. Speaker, P.O. Box 7, Boston, MA 02215.

For Sale

- *Revox A77 1/4-track tape deck; Teac AN-180 Dolby unit (4 cards, big meters); Advent 100A Dolby B unit with wooden case. Call (302) 856-5260 (days), (302) 684-3443 weekends or evenings before 9 PM EST.
- *Van Alstine Double Dyna 400 (actually a modified stereo 416 with LED display, handles, and 100,000 uF of external power supply). This unit was built by Jensen's Stereo Shop and is the very latest "zero TIM" version. Absolutely superb sound and incredible power and bass. Better than mint, but must sell. Call Chuck at (215) 623-0752 evenings or weekends.
- *Apt Holman preamp, \$375; Pioneer SD-1100 stereo/quad display (scope, meters, oscillator), \$300; Sherwood Micro CPU 100 FM tuner, \$1,000; BIC FM-10 Beam Box FM antenna, \$20; B&O 4002 straight-line turntable, \$500; dbx 117 compander, \$100; Soundcraftsmen 20-12 octave equalizer, \$175; Sony 3200F amp (100W x 2), \$200; Allison Ones, \$550/pair; all with manuals and cartons except for Allison cartons. Bob Sisk, (617) 973-7228 (days).
- *Rappaport AMP-1 power amp, \$850; no reasonable offer refused. Call (617) 456-8642 after 6 PM.
- *Quad electrostatic loudspeakers, \$900/pair; RTR ESL-6, \$250/pair; Decca ribbon tweeters, \$250/pair; Allison Model Fours, \$300/pair; Series 20 M22 power amp, \$400; Series 20 D-23 crossover, \$500; Dyna Stereo 70 power amp, \$150; Dyna Stereo 400 power amp, \$350; Sound Concepts SD-550, \$450. Call (617) 254-0697.
- *Phase Linear 200 Series II power amp, 120 W/ch, \$250; Phase Linear 400 Series II power amp, 210 W/ch, \$375; both one year old with original packing and manuals. Braun TG-1000 1/2-track stereo tape deck, in very good condition. I have outboarded the power transformer to eliminate hum. With both English and German service manuals, \$375. Call Ron, (617) 469-9688 before 11 PM EST.
- *Magnepan MG-2 speakers, \$425/pair; Technics SL-1500 direct drive manual turntable, \$70; both in excellent condition. Call John, (617) 273-3061.
- *Dyna PAT-4; Dyna PAS-2 (AA Mod.); PS Audio phono preamp, with new power supply caps; \$50 each as is; Heath IM-37, non-operative, \$30; Heath IM-48 (only AC VTVM tried), \$50; McIntosh MR-77 FM tuner, \$500. UPS delivery in Chicago only, except tuner. Box 22, Lansing, IL 60438.
- *Hafler DH-101 preamp, wired by present owner, works perfectly, never used, \$225. Call (617) 367-0185.
- *Denon AU-320 transformer for moving coil cartridges, 3 Ohm or 40 Ohm input, \$75 or best offer. Call Pete, (301) 585-9898, leave message on tape.
- *One pair KLH-9 electrostatic loudspeakers, in A-1 condition, \$600. (617) 762-0812.
- *Infinity Black Widow tone arm, \$160; Fons CQ30 turntable with two SME cutouts, \$90; M & K subwoofer with glass top, \$150 plus shipping, free delivery in Eastern Massachusetts or Rhode Island. Call Jeff, (617) 325-6311.
- *Speaker wire blowout: Monster Cable, 15 ft. pair, with spade lugs, \$10; Mogami, 7.5 ft. pair, 11 ft. pair, 3 and 5 ft. pieces, all for \$15; Monitor Audio Stylift, \$5; Pixoff (1/2 roll left), \$3. Art Scott, 10365 Wunderlich Drive, Cupertino, CA 95014.
- *Michaelson & Austin TVA-1, TVP-1, \$1500; Quad ESLs, \$800; Marcoff PPA-1, \$70; Supex SD 900 E plus, \$70. All as new, little-used or unused, in original cartons with manuals and warranties, Fried M/2s, all mods, excellent condition, \$1200; Philips G312, in carton, \$50. Buyer collects. (212) 724-9219.
- *Audio test equipment: Heath IG-18 audio generator, IM-12 harmonic distortion analyzer, AA-1 IM analyzer/AC VTVM, V7-A AC/DC/Ohms VTVM, all for \$100; 100 dB balanced attenuator, 1 dB steps, \$25. Also Dyna PAS-3x preamp, unmodified, good condition, new electrolytics, spare tubes, manual, \$25. Ron Roscoe, 62 Harris Street, Acton, MA 01720, (617) 263-8296 (evenings), (617) 493-6084 (days).
- *Audiopulse Model One time delay system, excellent condition, all papers and packing, \$400. L. Pierce, (617) 659-4366.
- *Audionics PZ3-2 power amp, 100 W/ch, black, rack mount, mint, without meters, recently factory tweaked, \$300; ADC Sound Shaper Two equalizer, mint, full 12 bands/ch, with meter, \$200; black Optonica RT 1515B cassette deck with APSS, mint, \$210; Archer triple-driven six element directional FM antenna, 110 miles, mint, and Winegard FM-340 signal booster, 18 dB gain, \$25; Quik-see album drawer on bearing slides, holds 80 LPs, brass wire construction, for built-in or cabinet installations, \$35. L. Barry Tinkoff, P. O. Box 590, Fall River, MA 02722, (617) 673-6622 (evenings).

Wanted

- *Sennheiser HDI 434 wireless headphones and SI 434 infrared transmitter, mint and reasonable; Brazilian rosewood cabinet for Sequerra tuner. L. Barry Tinkoff, P.O. Box 590, Fall River, MA 02722, (617) 673-6622 (evenings).
- *BAS member from Philadelphia who wants to sell Audiopulse and Lux adaptor, please resubmit ad and include name and address.
- *Apt preamp. (302) 856-5260 (days), (302) 684-3443 (evenings before 9 PM).
- *Quad AM-3 tuner; Thorens TD-124 Mk III turntable. John Johnson, 435 E. 70th Street, New York, NY 10021, (212) 628-2461.
- *Dyna stereo 120, working or not; stereo 150; schematic for KEF 101 crossover and protection circuit. Don Neal, 838 21st Avenue, S. E., Minneapolis, MN 55414.

Executive Committee Report

The Executive Committee met on March 1. An offer from Wireless World for an exchange of subscriptions was accepted. Al Foster reported that our Inquiry Response form letter has been printed, with the Real Paper's article about the BAS reprinted on the reverse side. It was decided that several hundred copies will be distributed to retail stores, to make local audiophiles more aware of the BAS. A notice about the BAS was published in the March 11 Phoenix for the same purpose, and ads about the BAS will appear in future hi-fi supplements to both papers (and in selected audiophile magazines).

It was decided to establish a permanent Program Committee and to poll members for recommendations regarding meeting subjects and other BAS activities. (A poll form was distributed at the March meeting and is available to other members on request.) It was decided to proceed with the purchase of the Ivie 10A spectrum analyzer although preparations for its distribution to members have not been completed. It was decided to make the Test Equipment Committee a permanent rather than temporary committee; its chairman, John Schlafer, thus becomes a member of the Executive Committee (which now has six members including Editor Brad Meyer and the four officers).

Several constitutional questions were discussed in order to provide recommendations to the constitution update/revision committee. A draft of the revised constitution and bylaws is scheduled to be available to members in April for comment and criticism.

Treasurer Henry Belot, Membership Secretary Frank Farlow, and mailing-label producer Jack Stevens share a large record-keeping workload with substantial redundancy. The Society's growth makes this burden increasingly awkward, so computerization is now being considered. The options include purchase of a computer, purchase of time-sharing terminals for use with an employer's computer, etc. The Executive Committee welcomes ideas and information.

The Executive Committee meets again on April 13.

-- Peter Mitchell

Schwann Reports 1979 Record and Tape Statistics

The publishers of the Schwann Record Catalogs have released their statistical analysis for 1979, and as you might expect, the data are not encouraging. New releases were down nearly 18% to 5,041 new LPs and 3,649 new tapes. Cassettes have now firmly surpassed cartridges by 2,100 to 1,549, although both categories are down substantially from last year.

Out of the 1979 totals, the 2,420 classical releases were divided as follows: 1,877 LPs, 10 cartridges (classical carts are DEAD), and 533 cassettes. Schwann shows releases from a seemingly incredible 683 separate labels. And, of course, most of these did not look at what was already available before they planned their release lists. There were ten NEW releases of

the Beethoven Seventh Symphony, for example, in addition to the 14 or 15 already extant versions. Yet, there still is not a single version of Elliott Carter's First Symphony.

The good word for BAS members is, of course, the dramatic increase in so-called "specialty" records, including digital releases. These totaled 177 new releases. In addition to the recognized "state-of-the-art" labels, such majors as Angel, London and RCA entered the digital field with a handful of items, and Vanguard and Columbia's digital entries will be along shortly. Prepare to pay more, with the high technology releases carrying list prices of \$9.98 to \$17.98.

-- Dick Lewis (Massachusetts)

Ball Corporation Replies to Stierhoff

I read Neil Stierhoff's comments in the July 1979 issue of the Speaker about the "Cure for Sound Guard Woes." Nearly all of the customer letters on problems get referred to me and I don't find any record of our having heard from him. I would be interested in hearing about his problem.

The Sound Guard Record Preservative rarely is the cause of surface noise and when it is we can usually identify the reason. I am just guessing, but I suspect Mr. Stierhoff's routine included a thorough cleaning of the records with our cleaner or some other one like the Discwasher. What can happen is that the cleaning fluid loosens up surface deposits on the record. If this fluid with the suspended materials is not fully removed from the record, as it should be, some dries on the record. The last area to dry is down in the grooves and the concentrated suspended material is redeposited in the most critical area. We can sometimes detect the problem visually by observing water spots on the ungrooved area adjacent to the label.

One other comment. Mr. Stierhoff may want to notify anyone to whom he has sold Scotch 1606 degreaser that the solvents in it dissolve vinyl records rapidly and can easily destroy them. I think the readers of the Speaker should know this because some of them may follow his advice, obtain the degreaser from other sources, and wipe out some of their records.

-- Dr. Virgil Friebel, Manager, Sound Guard Laboratory, Ball Corporation

Kudos for Acoustat

Not infrequently, we read in our audio publications of an unhappy experience some audiophile has suffered at the hand of a manufacturer or dealer, and the injured party has often voiced complaints in the BAS: Speaker.

I feel that it is equally important we make note when a manufacturer surpasses its obligation in order to please a customer. I have had such an experience recently. The company is The Acoustat Corporation, and in particular Mr. James Strickland, who gave much personal attention to my problem. I don't feel that I should give details, but simply wish to note that an amplifier problem was handled in a friendly, honest and sincere manner. Their product is an excellent one, and their service is no less. Acoustat has my sincere recommendation.

-- Jerome Tanous (Iowa)

Is Stereo FM High Fidelity?

I have delayed writing this letter for some time in the hope that I would be able to come to some optimistic conclusions. I have not been able to do so. Recently, I have spoken with station engineers of a number of FM stations in the Washington, D.C. area. I found that over 90% of the stations use Technics direct drive turntables and Stanton 681EEE phono cartridges. This equipment is chosen for, among other reasons, its ruggedness and reliability. From that point onward in the audio/RF chain, every station employs different components. I found one station

using an old Pilotone tube preamp and another using a Heathkit solid state preamp. Most were using electronics in a "black-box" way, with little knowledge of their contents. It was at this point that I started hearing of the following devices: A.G.C. amplifiers, equalizers, clippers, compressors, dynamic range limiters, limiters, high-pass filters, low-pass filters, dynamic presence equalizers, peak limiters, etc.

I believe you can get a pretty good idea of what these things do to audio signals. The general idea is to keep the transmitted sound clear, punchy and LOUD, with the hope it will be hard to tune out the station. In addition to the use of some or all of these devices, some of the stations employ only cassette tape or broadcast tape cartridges with built-in cueing and sequencing, compression, limiting and filtering for totally automated studio operation.

There seem to be several not-so-mysterious forces governing FM sound quality. The F. C. C. has its rules and regulations and enforces them. Station management has specific policies regarding programming and advertising, and has the attitude that the most important things are to remain on the air reliably and to produce the format regardless. Sound quality is not important. There is an attitude of apathy among station personnel, and it is their belief that the listening public in general is apathetic as far as sound quality is concerned. After all, about 90% of the listening is done using auto receivers, table radios, portables, etc. The F.C.C. is considering closer spacing of the station allocations which will result in still more degradation of the transmitted sound. Add to all this the interjection of atmospheric noise and interference. What can one expect?

Having acquired the information above, I decided to do some experimentation. I purchased a Technics direct drive turntable, a Stanton 681EEE, and a Kenwood KT-815 FM tuner. The Kenwood is a marvel of engineering design. It employs a pulse count detector, 5 gang front end, selectable IF bandwidth, double conversion IF, phase lock loop multiplex decoder with pilot canceller, and servo lock tuning, and has very impressive specifications. The tuner performs beautifully. Using this new equipment, I compared records played on the turntable with the sound of the same record played on the air via FM transmission. I have concluded that the sound obtainable via FM is completely independent of the type of turntable or cartridge used at the station. I have never heard anything so sad as one local station's attempt to transmit the sound of a high quality direct disc record. The dynamics of the recording were lost, along with clarity and detail. At least pops and clicks are of low incidence. It is a wonder the sound quality is as good as it is considering all the things in its path.

My final conclusion? Spending more than \$300 or so on an FM tuner is a waste of money. This is probably a good rule of thumb even in fringe reception areas; a good antenna, providing noise-free gain, is the proper solution to receiver performance.

-- E. C. Kapplinger (Maryland)

(Once again we see how lucky we are to have good FM source material in Boston. --Ed.)

Dynaco Mark VI Amplifier

As a general rule we avoid printing commercial announcements in the Speaker, but this one seems sufficiently special to be of interest. The Dyna Mk VI was the largest in Dynaco's classic series of vacuum-tube amplifiers, a 120-Watt single-channel unit in a large rack-mountable black chassis. Dyna's entire final inventory of Mk VI amps (in kit form only) was purchased by Jeffrey Goldman who is selling them in original factory packing at half their original list price. The amp contains huge power and output transformers, uses four matched 8417 output tubes, and is biased with the aid of a front-panel meter. To buy, send \$275 (plus UPS shipping for 55 pounds) per channel to Jeffrey S. Goldman, Synthetics Group, Two Bata Cynwyd Plaza, Bala Cynwyd, PA 19004.

-- Peter Mitchell

In the Literature

Audio, February 1980

- *Interview (p. 8): Soundstream digital wizard Tom Stockham on digital disc formats, the superiority of digital tapes over direct-discs, and the importance of reproducing ambience.
- *Audio ETC (p. 18): How distortions sound.
- *Behind the Scenes (p. 26): Digital recorders seen at the last AES convention.
- *Forum (p. 34): Holman points out big problems in Audio's Equipment Directory.
- *Another Look at TIM (p. 38): An engineering text on rational power amp circuit design.
- *Picking Capacitors (p. 52): Important reading for engineers on distortions caused by capacitors of certain kinds.
- *Equipment Profiles (p. 64): Audio-Technica Lifesaver anti-static anti-wear lubricant for records (an enthusiastic review on all counts). BIC T4M two-speed cassette deck (very flexible controls, performance good at both speeds). ADC Sound Shaper Two 12-band graphic equalizer (good performance and flexibility). Apt/Holman preamplifier (extremely high quality; remarkably sensible and useful controls, outstanding owner's manual; the review includes many novel tests, some of dubious relevance). BASF DIN calibration cassettes (very expensive, evidently they set the official standard; the report ignores the crucial question of whether these tapes agree with the widely-used TDK calibration cassettes).

The Audio Amateur, 1980 No. 1

- *Regulated Power Amp Supplies (p. 6): Good designs for amplifiers needing a regulated supply.
- *Dynamic Range and Clipping Indicator (p. 14): Dave White's LED meter with a 70 dB range.
- *Accurate Inverse RIAA Network (p. 22): For when you need accuracies of hundredths of a dB.
- *Conversation with Peter Baxandall (p. 27): Part 2; the old master pooh-poohs Ojala and says other good things.
- *Golden Ears or Iron Pyrites ? (p. 34): Details on a lengthy and carefully controlled A/B comparison of power amps in which no statistically different differences were heard.
- *Test Report (p. 42): An elaborate subjective comparison of the PAT-5/WJ-1A vs. an updated Levinson ML-1. The competition was found to be close.
- *Books (p. 46): A few good ones in the crowd.
- *Recordings (p. 50): Yes, TAA is now printing reviews.
- *Letters (p. 56): Lots, pro and con on A/B testing and other subjects.

Audio Engineering Society Journal, January-February 1980

- *Feedforward Error Correction (p. 2): You've heard of using negative feedback to reduce amplifier distortion. This is all about an even older idea now coming back: error feedforward to cancel distortion, without feedback's instabilities. Important reading for engineers.
- *Magnetic Fluids and Loudspeaker Design Parameters (p. 17): Theory and data on the virtues of ferrofluids in speakers.
- *The JE-990 Discrete Op Amp (p. 26): On a circuit which may prove popular as a high-performance mike preamp.,
- *Dipole Radiator Systems (p. 35): A multi-driver dynamic dipole speaker experiment which suggests that dipole woofers of reasonable size and good efficiency may be practical.

DB, February 1980

- *An Audio Microcomputer (p. 28): Describing the Barclay BADAP, a highly versatile spectrum analyzer with color video display and data processing which can, for instance, measure and display reverb decay vs. time vs. frequency, or the in-phase vs. out-of-phase spectra of a recording. Get ready to trade in your big Ivie analyzers.
- *Mitsubishi Digital (p. 33): About their open-reel PCM recorder and other hardware.
- *Electronic Digital Editing (p. 38): The editor for 3M's 32-track digital recorder.
- *Computerized Recording Console (p. 42): With 48-track recorders, mixing a rock record is now too complex for mere humans.

Gramophone (England), January 1980

- *Discs to Come (p. 1213): The Philips Compact and other digital audio disc systems.
- *Reviews (p. 1215): B&W 801 loudspeaker (adopted by EMI as a studio monitor; efficient, neutral, "one of the world's great loudspeakers"). dbx 2BX dynamic expander ("a joy to use").

High Fidelity, February 1980

- *Car Stereo Standards (p. 30): Leading makers of car gear vow to use standardized specs like those for home gear, described here.
- *Equipment Reports (p. 35): Tandberg 440A cassette deck (unorthodox design, excellent performance, strong bass, DYNEQ feature works well to prevent high-frequency distortion) Optonica 6905 cassette deck with RT6901 timer/controller (amazingly flexible programming, but the automatic program finder can be fooled; record/play performance very good; distortion graph mislabeled). Akai M50 cassette deck (very good performance for the price, flexible biasing, 3 heads with double-Dolby). Technics SL-B1 belt-drive manual turntable (at \$100 list a real "best buy" with few frills and very good performance). ESS Tempest Classic speaker (peculiar crossover controls, 4 Ohm impedance, plays loud, Heil tweeter yields nice imaging and detail, bass is thumpy). Shure SC39ED phono cartridge (a remarkable combination of ruggedness and fine performance).
- *Zen and Front-Panel Design (p. 54): The need for "human-engineering" of controls in place of mindless "cosmetics."
- *Cassette in Crisis (p. 61): On the coming chaos in cassette compatibility as patents expire.

Hi-Fi News & Record Review (England), January 1980

- *Assessing Amplifier Performance (p. 61): A rational approach to amplifier evaluation, ranking power in dBW and paying attention to audible frequency response errors.
- *A Simple 30-Watt Amplifier Design (p. 67): Details of the thought process used in designing a potent little high-current amp which will appear in kit form.
- *Quality Monitor (p. 78): Reassessing the best recent discs for sound quality.
- *Equipment Review (p. 131): A lengthy comparative study of eight pre/power amp combinations, all found to have audible deviations from flat frequency response and thus to sound different in comparisons. Despite a 10 to 1 range in price and rated power, their maximum effective output covers only a 7 dB range at 8 Ohms and a 5 dB range at 4 Ohms. BGW 103/410 (103 pre and 410 power amp, 350 watts/ch at 8 Ohms, falls down with more difficult loads). Pioneer 8800 integrated (excellent overall, accurate, good tolerance of load impedance). Quad 44/405 (44 preamp has extremely flexible input and tone control arrangements; 405 power amp good at high impedances, but aggressive output protection cripples it at 4 Ohms). NAD 3020 integrated (an outstanding design and clear "best-buy" especially with loads below 8 Ohms; outperforms the Quad 405 at 4 Ohms; soft-clipping feature works well). Exposure III/IV (expensive but good; preamp a stripped-down design with clean performance, power amp a solid design with no problems). SAE 3000/3100 (good performance; 3000 preamp has awkward controls, 3100 power amp has mechanical hum, otherwise fine). Rogers A-100 integrated (aside from a mechanical hum, a solid British design with good load tolerance). Sony TA-70F (compact and lightweight, likes only 8-Ohm resistive loads, has moving-coil input, measures well).

HiFi Stereophonie (Germany), January 1980

Several articles devoted to the record cover design and its contents:

- *The Aesthetics of the Record Cover (p. 8).
- *The Record Cover Liner Notes - A Chance or an Alibi? (p. 12).
- *The Excitement in Pictures and Words (p. 16): About how the cover of rock and jazz music records influences their reception.
- *The Berlin Jazz Festival '79 (p. 20).
- *Jazz and India (p. 26): The history, musicality, society and spirit.
- *The German Record Critics Award (p. 35).
- *Test Reports (p. 82): The GAS Thalia/Grandson and the Philips 22AH280SA/380PA preamplifiers and power amplifiers (both very good). The Accuphase T-103/E-303, the Sansui TU-X1/AU-X1 and the Sharp Optonica ST-5100/SM-5100 tuners and integrated amplifiers (having no apparent deficiencies, the TU-X1 becomes the reviewer's new reference tuner). The Audio Pro

B2-50 subwoofer (powerful and clean). The Luxman Monitor MS-10 (neutral and uncolored, even for "European" ears). The Acron 400B, 300C, 300B, 200C and 200B loudspeakers (good, especially the largest, the 400B). The Canton GLE 100, 70, 60, 50, 45 and 40 loudspeakers (very fine, justifying the high reputation gained by Canton).

Modern Recording, February 1980

*Lab Reports (p. 76): Soundcraftsmen AE2420 equalizer-analyzer (graphic equalizer is fine; spectrum analyzer function is peculiar, owner's manual poor). BIC T-05 cassette recorder (very good at the price). Apt 1 power amplifier (rugged, potent, super-clean). Neptune 2709 1/3 octave spectrum analyzer (it works well but they don't like it). DeltaLab DL-2 Acousticomputer stereo digital delay line (sounds superb, very flexible, elaborate special effects and reverb as well as delay).

Popular Electronics, February 1980

*Whither Digital (p. 20): Musings on developing digital systems.
*Test Reports (p. 28): Rotel 2100 FM tuner (excellent performance in wide and narrow IF, sensitive multipath display, useless signal-strength display). EPI 500 loudspeaker (wide range, neutral balance, crisp top, impressive bottom, imaging is detailed rather than spacious). RG Dynamics Pro 20 dynamic expander (effective without audible side effects).

Boston Phoenix, March 11, 1980

*The Sound Ideas supplement includes feature articles on FM inventor Edwin Armstrong, the NPR satellite, tape formats, the coming chaos in cassette compatibility as Philips patents expire, a report on new products at the Winter CES, and an interview with Advent's new chief, Bernie Mitchell from Pioneer.

Radio Electronics, February 1980

*Audio Level Meter (p. 43): Details on a homebrew \$50 stereo LED power meter.
*Backyard Satellite TV (p. 47): Details on making the large antenna.
*Improved Sound Quality (p. 64): Details on a new TV sound receiver circuit with much improved immunity to distortion and video interference.
*Turntable Specifications (p. 66): Background on the new Thorens technique for measuring rumble independent of cartridge/arm resonance.
*Review (p. 69) Technics RS-M7 cassette deck (pretty good at the price).

Stereo Review, February 1980

*Audio News (p. 22): Notes on new stuff seen at the Tokyo Audio Fair.
*Audio Q&A (p. 24): About MOSFETs, nuances, diamonds, and a pun.
*Audio Basics (p. 26): Really basic intro to volume controls.
*Tape Talk (p. 28): Solid answers to common questions.
*Technical Talk (p. 35): AFC, quartz-lock, and other FM tuning aids past and present.
*Test Reports (p. 36): ADC Sound Shaper Three graphic equalizer (expensive but good, adjustable center frequencies yield useful flexibility). Realistic 2200 receiver (digital frequency synthesis tuning, fine tuner performance, good tone controls, preamp good except for deep-bass rolloff, power amp fine with good tolerance of load impedances). Beyer 440 headphones (comfortable, smooth, good highs). JBL 150 speaker (inefficient by JBL standards, lots of clean deep bass and top end). Crown SL-1 preamp and PL-1 power amp (stripped-down design, phono module located at turntable -- an excellent idea, preamp performance generally superb; power amp overpriced, performs well except for limited current output).

-- Peter Mitchell and Jiri Burdych

January BAS Meeting

Business Meeting and Open Forum

The meeting convened at GTE shortly after 6:00 PM on January 13. Frank Farlow described the work of the BAS Constitution Committee, which comprises Dave Bredemeier, Jim Thoroman, Larry Kaufman, Peter Mitchell, and Frank. The Committee has decided that the constitution must be rewritten, not just amended. The proposed new document is included in this issue of the Speaker and will be voted on at the May meeting.

Peter Mitchell had just returned from the January CES, having heard the dbx-encoded, digitally mastered discs recorded in Europe by M & K. There are six records in this series, and the first pressings of Volume 3, purported to contain music by Bizet, Rimsky-Korsakov, and Ginastera, had the Ginastera work pressed onto both sides of the disc by mistake. The mistake has probably been corrected by now, so hang on to that record if you have it; it will doubtless be very valuable when the gold market collapses, and of course the music that is there will last twice as long.

Dick Glidewell had the Audio Control spectrum analyzer for sale to BAS members at a discount. He also announced that the Hafler power amp had just gone up in price; he still has them for his old price of \$299, but he expects a delay of about two months in getting units. Al Foster announced plans to hold a BAS power amp clinic, to include tests under a wide variety of signal and load conditions. He also gave the results of his bench tests of a prototype Carver amplifier, which appear at the end of this meeting report.

At this juncture Peter Mitchell offered the crowd a choice of hearing an hour or so of reports on the CES, or going straight to the scheduled guest speaker. Probably because the subject had been covered on the previous day's Shop Talk, the unusually large crowd (attendance was around 120) chose instead to hear, without delay, Bob Carver give the first public technical description of the Carver Electronics magnetic amplifier.

Meeting Feature - The Carver M-400 Power Amplifier

The story of the magnetic amplifier begins just over two years ago, shortly before the January, 1978 CES. Bob Carver had just been ousted from Phase Linear in a boardroom coup. He went to the CES, staying with an acquaintance from ESS because the room he had reserved was unavailable to him. He was sitting outside the hotel, feeling very sad, when a manufacturer's rep named Les Davis introduced himself. Having heard Carver's story, Davis offered encouragement and support, assuring Carver that he could make a strong comeback within a year. The timetable was slightly optimistic but the prediction has proved correct.

"I knew I had to have a really great idea, " said Carver, "or two, maybe ..." (much laughter). The first idea was inspired by a clock he saw at Tiffany's in the shape of a lustrous golden cube, which gave him the notion of trying to build a high-powered amplifier in a similar package. The final result is amazingly small and light, contains three printed circuit boards, uses no exotic parts, has a transformer made of ordinary materials (albeit of unusual design) which is about the size of the transformer in a conventional 20-Watt amp, contains no heat sink other than the chassis, and offers for \$349 almost identical performance to the original Phase Linear 700, which cost \$800 ten years ago. It is conservatively rated at 200 Watts per channel continuous power into 8 Ohms, and will put out over 300 Watts into both 4 and 2 Ohms. Unlike the original Phase Linear, it will deliver lots of power into an electrostatic loudspeaker. It can be bridged to operate as an extremely powerful monaural amplifier without additional hardware. Its dynamic headroom is about 2 dB.

The Power Supply

The unusual power/weight and power/cost ratios of the magnetic amplifier are the result of two things: an efficient power supply and an efficient output stage. First, we will discuss the power supply.

Figure 1 shows the power supply circuit of a conventional power amplifier, consisting of a power transformer, a bridge rectifier, and two filter capacitors. The peak value of the rectified voltage determines the voltage of the supply. In its quiescent state, i.e., when no power is being drawn, no current flows through the rectifier. When the amplifier starts feeding power to the load, current is drained from the capacitors and their voltage falls slightly. The rectifier then conducts during the portion of the wave in which the voltage is higher than the voltage on the capacitors. Because the voltage on the capacitors never drops by more than about 20%, even at maximum output, the portion of the 60 Hz waveform during which conduction takes place is quite small. In this design, all the energy is stored in the electrical field of the capacitors. The power transformer has to be big, because at full power it is required to provide 120 short bursts per second of very high current, but its capabilities are underused because the conduction angle is small.

Figure 2 shows one of Carver's early attempts to build a more efficient amplifier, which he used to introduce the concept of the magnetic power supply. Superficially, the elements of the circuit are the same as in the conventional circuit: a transformer, a rectifier, and a filter capacitor. Here, however, there is a triac in series with the primary of the transformer. A triac is an electronic switch, controllable by an external voltage; it turns on and off during each half cycle of the 60 Hz wave. This intermittent operation causes the transformer to behave like the ignition coil in a car, as a field coil rather than as a transformer in the usual sense. When the triac conducts, current flows in the primary, and a magnetic field builds up. The triac is turned off as the voltage crosses zero, which is the point at which the current, and hence the magnetic field, is at its peak. The resulting collapse of the field produces a very high voltage in the secondary, which is then rectified to charge the filter caps. By properly controlling the triac, the conduction angle can be made much larger than in a conventional design, increasing the efficiency substantially, and allowing the use of a smaller transformer to produce the same voltage and current output. This is a "magnetic" power supply, because it first stores energy in the magnetic field around the primary coil, then dumps the energy into the capacitors.

Figure 3 shows the final version of the magnetic power supply. The power transformer, now called the field coil, is approximately one fifteenth the size and weight of the transformer in the original Phase Linear 700, and puts out nearly the same power. "It's not so much that this one's unbelievably small;" Carver says, "it's that a conventional transformer is unbelievably large." In this design, the field coil is chosen to have lots of leakage inductance, which in the figure is drawn separately from the secondary. There is a connection from the filter capacitors to the triac which causes the triac to turn off before the zero crossing. As before, when the triac turns on, current flows and a magnetic field builds up in the field coil. In this version, there is a capacitor in the secondary before the rectifier. This capacitor combines with the leakage inductance of the field coil to form a resonant circuit. When the triac turns off, the secondary circuit, instead of producing a single large pulse, goes into oscillation at a frequency of around 600 Hz, and its stored energy is then transferred through the bridge rectifier into the filter capacitors. Because the frequency at which this takes place is relatively high, the caps can be smaller and still do an adequate job of filtering. When heavy power demands drain the filter caps; the triac stays on longer and the conduction angle increases.

Another clever scheme that helps make the most efficient use of the power supply is that the two channels of the amp are operated out of phase, so that the "+" loudspeaker terminal of one channel is at ground potential. The heaviest demands fall on the power supply during passages with heavy bass, and in most recordings the lowest bass is made to be monaural to allow easier cutting and tracking of the disc. When the same signal is fed to both channels, one will swing positive while the other goes negative. In this way the positive and negative halves of the power supply each take care of only one channel at any instant; in a normal power amp both channels would be drawing current from half the supply while the other polarity lies idle.

The presence in the primary of the triac, which controls the power supply in response to an externally applied voltage, gives the designer a chance to use protection circuitry that is effective without compromising the amplifier's performance. Carver assumes, no doubt correctly, that the low price of the unit will attract many customers who have never before owned a high-power amplifier, and who are unaware of the dangers. Accordingly he designed the M-400 to resist the most deliberate attempts to blow it up. The amp will shut down if either output voltage, output current, or their product becomes excessive. The VI limiting does not take effect until

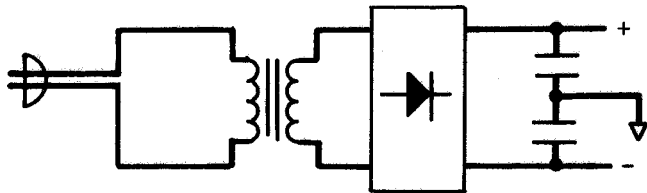
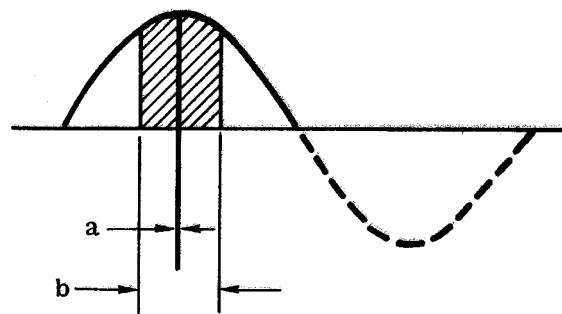

Fig. 1. Conventional power supply



Conduction angle

a = No load

b = Full load (15% voltage sag)

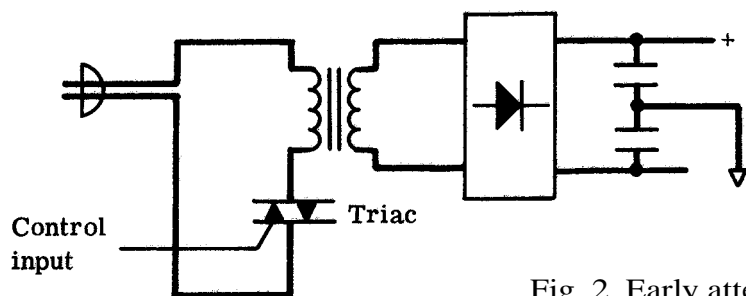
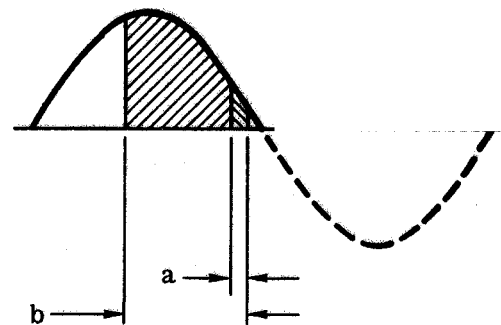
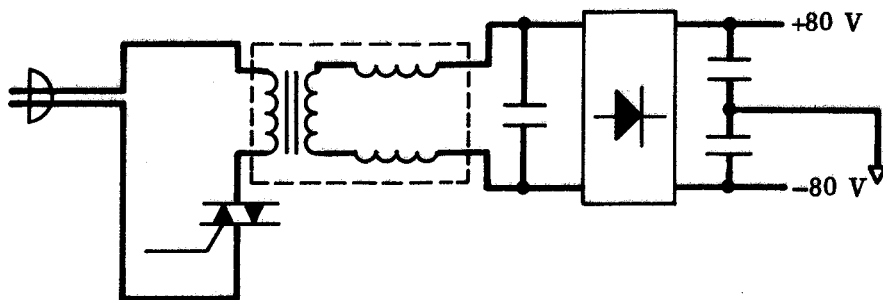

Fig. 2. Early attempt at more efficient power supply



Conduction angle

a = No load

b = Full load

Fig. 3. M-400 power supply

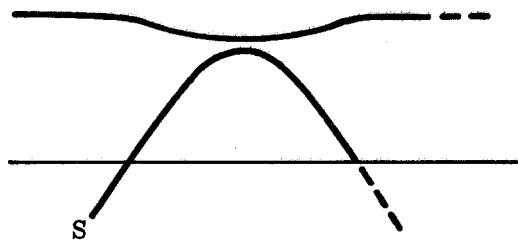

(a) Conventional amplifier

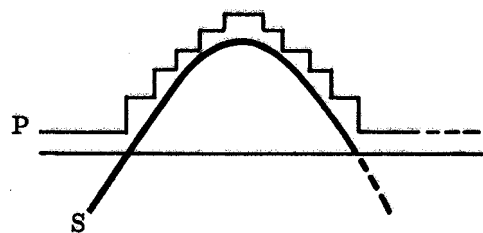

(b) Carver M-400

Fig. 4. Power supply (P) and signal (S) waveforms

the current reaches 15 Amps/channel, and will allow for a load line with an imaginary:real ratio of 2:1 (i.e., it will drive typically reactive speaker impedances). Too high a temperature will shut it down, as will the presence of more than a few millivolts of DC in the output. There is a circuit which, in effect, estimates the voice coil temperature of the speakers and prevents them from overheating. This function is frequency-dependent, so that it protects midranges and tweeters more stringently than woofers. It doesn't sense the very highest frequencies, though, because that would cause the amp to shut down during the FTC preconditioning routine; instead it guesses at the power being delivered to the tweeter by looking at the midrange. It is therefore possible to burn out a tweeter by feeding it high frequency pure tones. This thermal protection for the speakers is provided by a circuit that integrates the voltage over the previous two minutes or so and shuts things down if the average power gets too high.

The final, and perhaps the most interesting, protection feature is one which shuts down the power supply in response to large amounts of out-of-phase infrasonic material. According to Carver, this circuit does not give trouble on actual music, but it renders the system immune to dropping the stylus with the gain up, because that accident produces a huge out-of-phase thump.

The Output Stage (or, Throw Away That Heat Sink!)

The diagram in Figure 3 shows a single 80-Volt power supply. In reality there are three separate supplies in the M-400, each with its own bridge rectifier. The others put out 50 and 25 Volts, and there are switching transistors which provide intermediate values of 65 and 37.5 Volts. In all, there are five different voltages to which the B+ and B- connections can be made, and the amp contains an electronic switch which Carver calls a commutator that chooses among the values according to the demands of the input waveform. The difference between this mode of operation and the usual one can be seen in Figure 4. The behavior of the conventional circuit is shown in Figure 4a. When power is demanded from the amp, the B+ falls slightly, and the ripple increases somewhat. As more power is drawn, the signal and the B+ get closer together, and when they touch, the amplifier clips. In Figure 4b we see the M-400 responding to a high level, low frequency signal: the power supply voltages track the signal up and down. The most important feature of this diagram is that the vertical distance between the power supply and the signal voltages, which determines the amount of power that is dissipated in the transistor, is large in the conventional amp, and small (never exceeding about 15 Volts) in the M-400. The output devices are operated in non-switching class B mode, which prevents crossover notch distortion but usually makes an amp run hot. Here, however, the dissipation is low, particularly at moderate power levels where conventional amps dissipate the most power in their transistors. The M-400 is 33% more efficient than a typical conventional unit at full power, and about 300% more efficient at one-third power.

Similar schemes for obtaining both high peak power and low quiescent dissipation have been used by Hitachi ("class G") and Soundcraftsmen ("class H"). The Carver design falls somewhere between these simpler forms and the so-called "smart power supply" amps in its degree of approximation of the signal by the B+. The extra components needed for the more sophisticated designs increase the complexity and cost of the circuit, but, as Carver says, silicon is cheap compared to copper and iron, and silicon can be made to have a certain rudimentary form of intelligence. The M-400 exemplifies the substitution of intelligence for brute force. In response to a question about the feasibility of smaller amps being made in this way, Carver pointed out that the savings are greatest in a high-powered amp, because that is where the most copper and iron can be eliminated. The power supply of an ordinary 30-Watt amp is cheap enough that trimming some copper and iron from it would not save enough to pay for the added complexity of the Carver design.

There is, however, a larger magnetic amplifier on the drawing board. A member of the audience observed that the high power to weight ratio of the M-400 seemed to make it ideal for a traveling rock band. Carver's reply is that the present model is optimized for home hi-fi use, and that its protection circuitry would be a source of constant irritation and puzzlement to rock-and-roll sound men. He is designing a professional model, with higher rated power, to meet this need. (Member of audience: "Since the professional model will have a higher rated power than this one, how do you propose to keep audiophiles from buying it?" Carver: "I don't know. Maybe I'll make it very ugly." Audience: "That never stopped them before ...")

Carver considered using a high frequency switching power supply before he thought of the present design. He shied away from this approach for several reasons: complexity, cost, unreliability, and interference. A 20 kHz supply uses high frequency switching transistors which, in order to be fast enough to do the job, have to have very thin base and emitter layers. These thinly deposited layers can be broken through easily by relatively small overvoltages, so the failure rate is high. The transients generated in a 2 kiloWatt, 20 kiloHertz switcher are tremendous, necessitating a massive shield held together by screws one-quarter inch apart. As the projected retail price of the unit climbed past \$1,800 with no end in sight, Carver realized that he was on the wrong track.

Carver offered the supposition that many engineers in the audience must be a bit disappointed to find no exotic or mysterious parts inside the M-400. But he pointed out that the unit had to be made of ordinary pieces, and not very many of them, if it was to gain the rapid acceptance that he wanted for it. The conventional designs against which it is competing have undergone decades of refinement, and the new approach had to have obvious advantages from the very beginning. The M-400 has an unusual shape, an unusual name, unusually light weight, and the alluring veil of mystery over its design. With this presentation, the veil was lifted, to reveal a design of such obvious merit that we were moved to wonder why it hadn't been done before. Carver said that he had heard that question a lot, and that he didn't know the answer.

After a brief intermission, during which an M-400 supplied some loud music at the front of the room, Carver answered questions from the audience about the Sonic Hologram preamp (reports are coming in that it works with all kinds of speakers, even the Bose 901, although omnidirectional speakers as a class are the worst; a less expensive unit containing the preamp and the hologram, but not the other features, will be out in about a year). A BAS member asked about building his own magnetic amplifier and was told that the circuit diagram will be available, but that Carver saves enough on parts by buying them in large quantities that the builder would probably realize no cost advantage by doing it himself. Finally, he was asked if he had any other bright ideas in the works. He replied that he did have a third one, and when someone from the audience asked, "Is it bigger than a breadbox?" someone else remarked, "It used to be."

-- Brad Meyer and Peter Mitchell

First Impressions of the M-400

Al Foster ran some bench tests on a prototype of the M-400 the day of the meeting. The perils of testing prototypes are many, but a brief look at one of the first production models has revealed no big differences. With both channels driving resistive loads, the prototype M-400 put out 276 Watts (continuous) into 8 Ohms, 361 Watts into 4 Ohms, 312 Watts into 2 Ohms, and 202 Watts into 1.1 Ohms. In the bridged (mono) mode, using a tone burst consisting of a single cycle of 1 kHz with a duty cycle of about 0.5%, peak power readings of 756 Watts into 1.1 Ohms and 1,024 Watts into 4 Ohms were obtained. At 12.5 Watts into an 8 Ohm resistive load, the distortion (THD) was 0.05% at 1 kHz and 0.047% at 20 kHz.

A brief listening comparison was made at my house between another Carver prototype and a pair of Audionics CC-2s operating in bridged mode, driving a pair of Snell Type A speakers, which have an impedance of roughly 4 Ohms. I played a tape recording of a thunderclap, which has a very brief, high-intensity peak with its greatest energy in the 125 and 160 Hz one-third-octave bands, and measured peak sound pressure levels. The peak is so brief that it is easy to light the clipping indicators on any amp I have tried without the sound being uncomfortably loud. In this test, the Carver was from 0 to 1 dB louder than the Audionicses (Audionices?) which, considering the 60% cost saving, is very good indeed. The CC-2s have a mechanical hum which is annoying at night when the room is very quiet; the Carver had the same problem, compounded by the presence of higher harmonics because of the switching in the power supply. Carver is aware of this problem, and has apparently fixed it in the production version.

There was only one piece of musical material on which the two amplifiers seemed to behave very differently: the M&K organ record entitled "The Power and the Glory," Volume 2. This disc has substantial amounts of energy below 20 Hz cut into it, and because it was made with spaced omnidirectional microphones much of the deep bass is out of phase. This caused the M-400's 0 dB LED to light at levels 10 dB or so lower than the CC-2's, and what was either clipping or power supply limiting could be heard at sound levels that were only moderately high. It

must be said, however, that the extent of the low bass on this record, and its randomness of phase, are positively freakish, and that on normal musical material the Carver could play louder than I wanted to listen.

The man who brought over the Carver and I did some listening comparisons with music, using the archaic molasses-slow A-B technique, with only a cursory attempt at level matching. We agreed that the amps sounded very similar, but not exactly alike. He preferred the CC-2s very slightly over the Carver, while I liked the Carver a bit better. Our impressions of the difference were similar as well. The CC-2s sounded warmer (if you preferred them) or more veiled (if you didn't), while the Carver sounded more transparent (if you preferred it) or slightly strident (if you didn't). Frequency response measurements, taken while the speakers were attached, showed differences of about 0.3 dB whose character coincides rather well with our informal subjective judgments. Because the Carver is a prototype, the measurements say more about the correspondence between subjective impressions and measurement than they do about the performance of the M-400, so the graphs in Figure 5 are not labeled by name; you must read the text to identify them.

-- Brad Meyer

Postscript: Bob Carver has provided an explanation for the behavior of the M-400 on the M & K organ record. It seems that the prototype amplifiers have signal-sensing circuitry which responds only to the positive half of the waveform. When the bass is monaural this is no problem, because the demands on the two halves of the supply are symmetrical. With out-of-phase bass the negative half encounters a wide voltage swing without any large signal in the positive half, so the triac never gets the message and the required voltage increase does not take place. The amp therefore clips much sooner than it otherwise would. Production units sense both sides of the supply; Al Foster has tested one of these with two oscillators, one for each channel, running at slightly different low frequencies, and reports no loss in power output. -- EBM

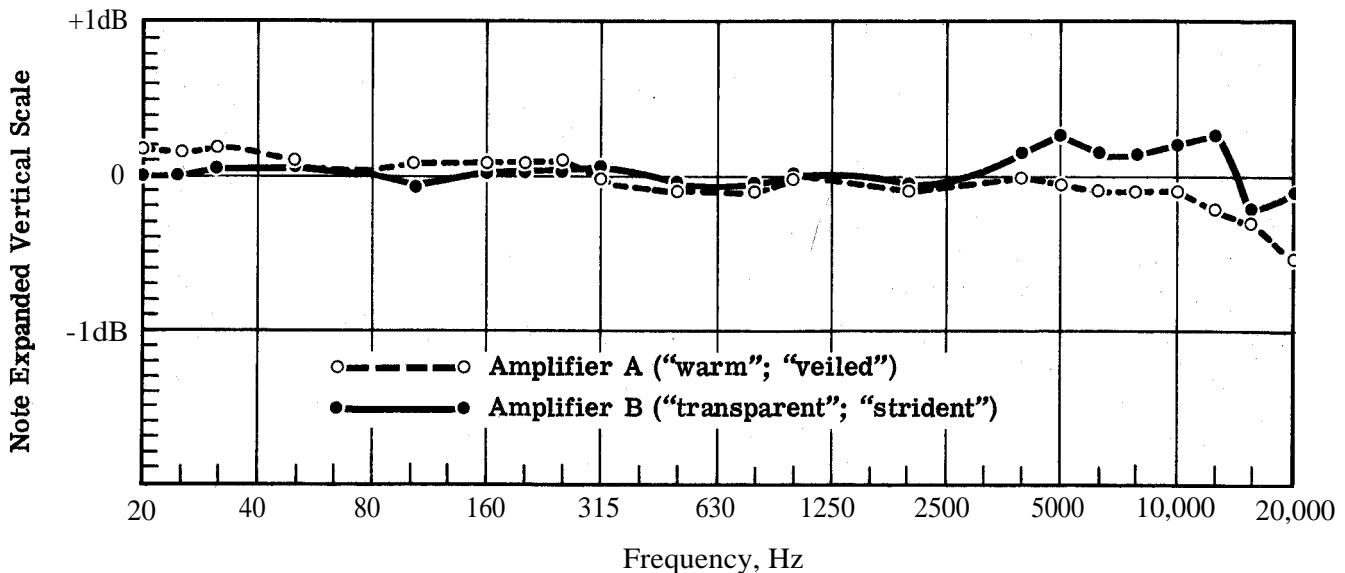

Fig. 5. Frequency response of Carver M-400 and Audionics CC-2

The Boston Audio Society does not endorse or criticize products, dealers, or services. Opinions expressed herein reflect the views of their authors and are for the information of the members.

A Test Report of the BAS

Report of the BAS Turntable/Arm/Cartridge Clinic

Part 2

Alvin Foster, J. K. Pollard, and Brad Meyer

Introduction

The second part of the turntable/arm/cartridge report contains the results of the tests of tone arm/cartridge resonance, rumble, acoustic isolation, and mechanical isolation. These factors, which are too often considered to be independent of each other, are actually closely inter-related.

In an ideal world, the cartridge would always be centered above the groove at the exact height which provides the proper deflection of the stylus cantilever. That this is often not the case is due to several factors. The first is that the arm and cartridge have mass, and they are resting on the compliant cantilever suspension, which is a spring. When such a system is perturbed, it vibrates at a frequency which is determined by the mass and the compliance. The higher the mass, and the higher the compliance (i.e., the softer the spring), the lower the resonant frequency. Obviously, the resonance should be kept out of the region which contains musical material, or there will be an audible bump in the response. At first glance, it looks as though all we must do is keep the resonance well below 20 Hz and everything will be all right.

Unfortunately, we then run into the second factor: records in the real world are not flat. Almost all have some warp, and statistical analyses of large numbers of records show that the worst warps occur between 2 and 5 Hz, falling off fairly rapidly in level above the latter frequency. When the arm and cartridge resonate, the cantilever deflects, and this moves the stylus back and forth along the groove, at the resonant frequency, for vertical movement, and at twice the resonant frequency, for horizontal movement. Movement along the groove, which is actually movement in time, produces flutter, and unfortunately the ear/brain is most susceptible to flutter at 4 Hz. The resonance cannot be made lower than 3 Hz, because the cantilever suspension would be too soft to move the arm across the record without deflecting violently. Besides, such a system would try to track the warps as if they were signals, and the warp amplitudes are sometimes so great that the stylus would retract into the cartridge body. The resonance must therefore be confined to the rather narrow range between 5 and 20 Hz. Exactly where in that range the resonance should fall is still under debate. Recommendations range from as low as 9 Hz to as high as 18 Hz, and the most popular estimates fall between 10 and 14 Hz.

The situation is complicated somewhat by the fact that there are sometimes two separate resonances in the system, one horizontal and one vertical. We can assume that the arm has very nearly the same effective mass in both directions (except for designs like the Vestigal and the Dynavector which have small subassemblies, that pivot only vertically, placed out at the end of an arm that pivots only horizontally). Cartridges, however, frequently have different compliances in the two directions. Where this is the case, the vertical compliance has been lowered to help the cantilever suspension support the arm. We measured only the horizontal resonance in our tests; the vertical resonance may be the same, or may occur at a somewhat higher frequency.

There are other sources of unwanted motion besides record warps. Vibrations transmitted to the record surface or the tone arm from the motor, drive components, and bearings of the turntable, collectively known as rumble, can cause audible problems if the turntable is incorrect-

Table 1 - Key to Sample Numbers,

Sample	Turntable	Arm	Cartridge
1	Linn-Sondek	Mayware Formula IV	AKG P8E
2	Connoisseur	Mayware Formula IV	AKG P8E
3	Sony PS 8750	- - - - -	Audio Technica AT-15Sa
4	Denon DP-2800	SME 3009-II	Denon DL-103-D
5	Kenwood KD-500	Mayware Formula IV	Denon DL-103D
6	Braun PS-600	- - - - -	Denon 103D
7	Thorens TD-126C Mk. II	- - - - -	Denon DL-103S
8 -	Lux PD- 121	SAEC	EMT
9	JVC JL-A40	- - - - -	Grado G-1
10	Ariston RD- 11S	Grace 707	Grado G-2+
11	Thorens TD-166 Mk II	-	NAD 9000
12.	Thorens TD-125	Mayware Formula IV	Ortofon M-15E Super
13	Harman-Kardon ST-7	- - - - -	Ortofon M-15E Super
14	Empire 398	- - - - -	Ortofon M-15E Super
15	Linn-Sondek	SME 3009 II (damped)	Ortofon MC-20
16	AR Xa	- - - - -	Shure V-15 Type II
17	Dual 721	- - - - -	Shure V-15 Type III
18,	Technics SL-1300	- - - - -	Shure V-15 Type III
19.	Thorens TD-125C Mk II	- - - - -	Shure V-15 Type III
20	AR Xa (modified)	Rabco SL-8E	Shure V-15 Type IVG
21	Prototype	Prototype	Shure V-15 Type IV-G
22	Yamaha YP-D8	- - - - -	Signet TK-7E
23.	Fons CQ-30	Decca International	Sonus Blue (old)
24	AR Xa	JH Formula IV	Sonus Blue (old)
25	Fons CQ-30	Mayware Formula IV	Sonus Blue
26	Harman-Kardon ST-8	- - - - -	Sonus Silver P
27	Philips GA-212	- - - - -	Stanton 681EEE
28	Kenwood 550	- - - - -	Stanton 881S

ly designed or manufactured. And in the real world, the shelf or base on which the turntable sits is not motionless; vibration is transmitted into the system this way, as well as from the sound field in the listening room, which can vibrate the base, the arm, or the record. All of this vibration is passed through the "peaking filter" of the arm/cartridge resonance before it enters the preamp as an electrical signal. In addition the acoustically and mechanically transmitted vibration will be augmented by any resonances in the suspension of the turntable.

The final thing you need to know about resonances to make sense of these data is that the height and width of a resonance are determined by how much damping there is in the system. In a mechanical system, damping is friction. A totally undamped resonance would occur only at a single frequency; the peak in the response would be infinitely high, and once excited the system would continue to vibrate forever. As damping is added, the range of frequencies showing a rise in response spreads out, the peak gets lower, and the resonance dies out more quickly when the excitation is removed. In the case of the arm/cartridge resonance, the need for damping is widely recognized, but there are many different ways to achieve it. Most cartridges have some damping built into the cantilever suspension: the springy material that holds the cantilever in place generates internal friction when it is flexed. Devices like the Distraker or the Stanton or Shure brushes add varying degrees of damping external to, but near, the stylus assembly. Some arms have damping, usually in the form of viscous silicone fluid around the bearings or pivots, and sometimes (as in the BAS-inspired SME) in the form of a small paddle that rides in a trough of silicone fluid.

It is important to have the proper amount of damping; too much damping will produce an elevation in the response too far below and above the resonant frequency, as the response curve flattens and broadens.

To sum up, important things to keep in mind while looking at turntable data are: the turntable, arm, and cartridge form a system whose properties derive from the combination of the parts, not just from the parts themselves; the system consists of a series of masses and springs with various resonances; these resonances color the output of the system; and the colorations are in most cases so severe that conventional measurements of rumble and flutter are mostly measurements of the location and amplitude of the resonances. These points are made and documented in the Bruel and Kjaer paper, "Audible Effects of Mechanical Resonances in Turntables," available from B & K Instruments, Inc., 5111 West 154th Street, Cleveland, OH 44142. Although one might quarrel with some of the recommendations in this paper, it contains much valuable data and is quite thorough. The B & K application note concludes that the traditional manufacturer's specifications for rumble and flutter are unreliable and inadequate. They point out the degree of interaction between turntable, arm, and cartridge, and stress the necessity for choosing these items with regard for compatibility. The region below 20 Hz, which affects rumble and flutter as well as mechanical and acoustical isolation, is important to turntable performance, especially, according to B & K, with respect to listening fatigue. This region of the spectrum has to date been largely guessed at or ignored by many manufacturers.

Tone Arm Resonance, Rumble Spectrum, Acoustic and Mechanical Isolation

Table Chairmen - J. K. Pollard and Alvin Foster

Data Reduction - J. K. Pollard, Alvin Foster, Brad Meyer, and Peter Mitchell

Authors - Alvin Foster, J. K. Pollard, and Brad Meyer

Tone Arm Resonance

To measure tone arm resonance, the equipment set-up shown in Figure 2 was used along with B & K test record #QR 2010. This disc contains a laterally cut sweep from 5 to 20 Hz lasting about 30 seconds, recorded at 1 cm/sec (-20 dB with respect to B & K's arbitrary 0 dB level). This subsonic sweep is immediately preceded by a 1,000 Hz tone of brief duration for use as a cue signal. In our tests, a 0 dB 1 kHz tone on Band 3 of the B & K disc was played first while the gain on the preamp was adjusted to bring the recorded pen to the top of the graph paper (0 dB). The tone arm was then moved to the resonance test band. At the instant the 1 kHz cue tone ended, the operator triggered the sweep generator. From that point on, the recording of the resonance graph proceeded automatically.

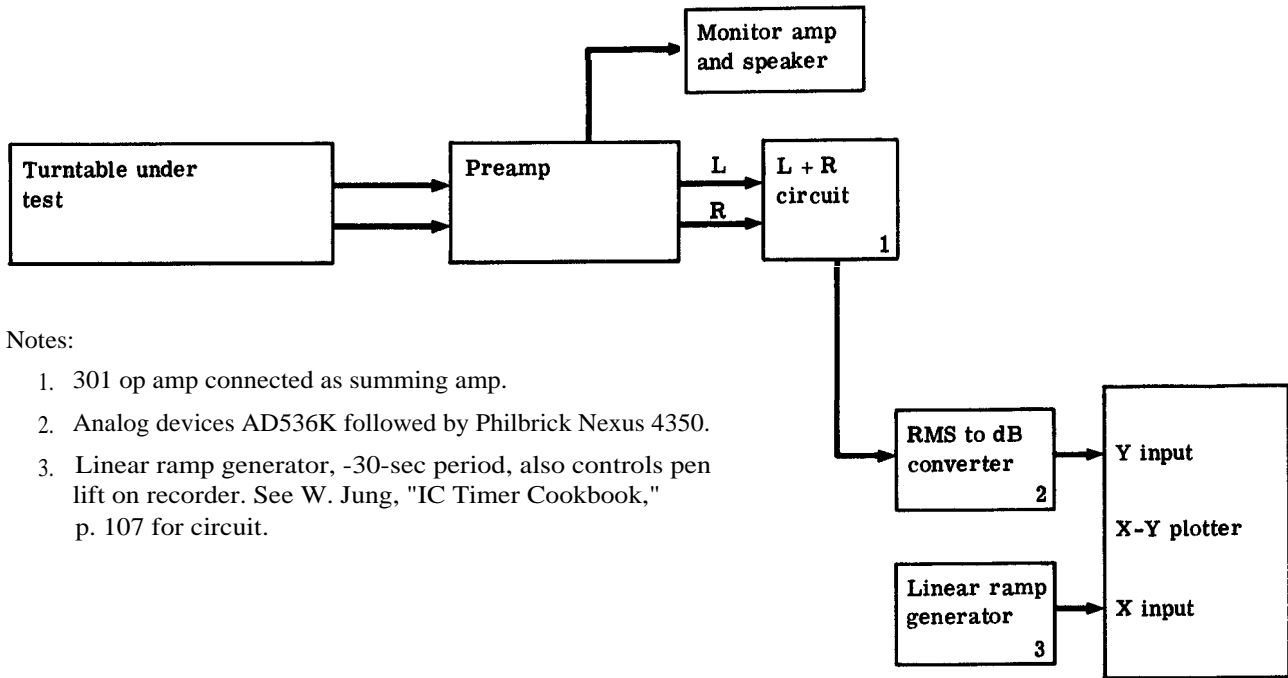

Fig. 2. Test setup for arm resonance

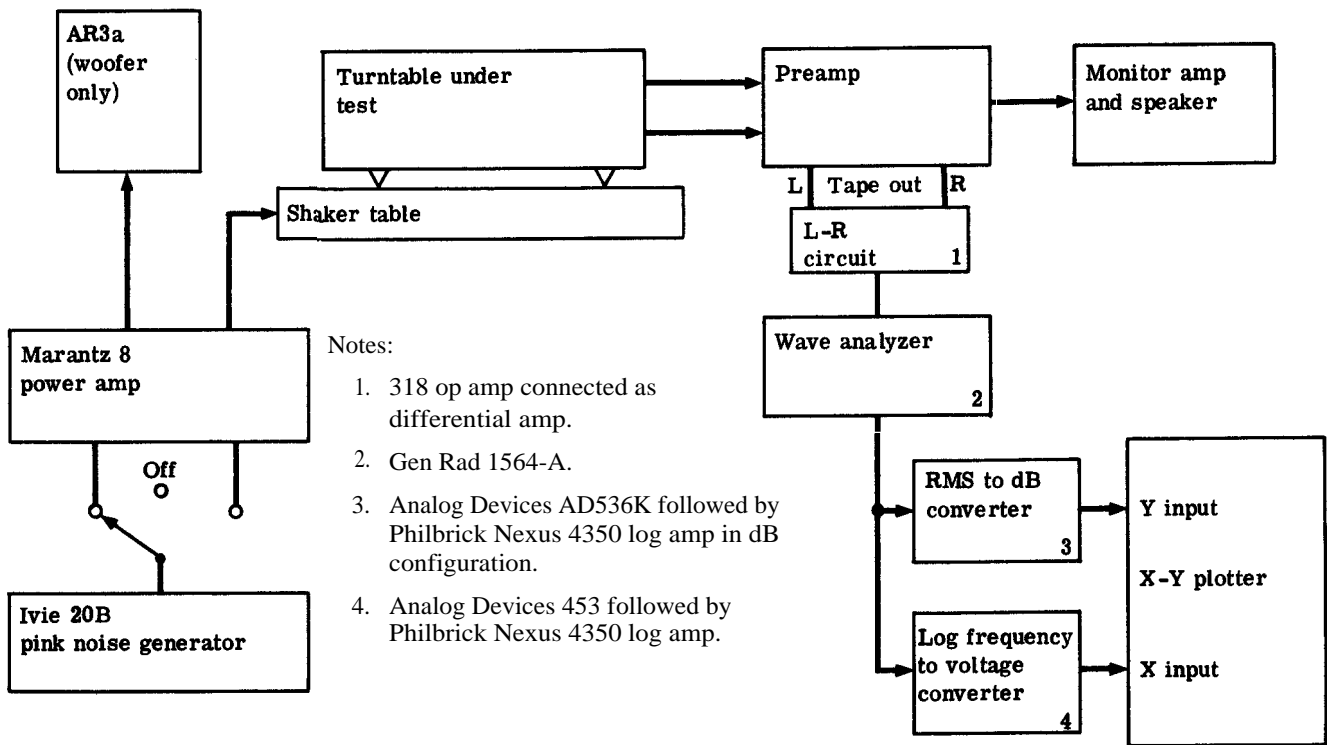

Fig. 3. Test setup for rumble and for acoustic and mechanical isolation

Rumble Spectrum

With the test set-up of Figure 3 and the Ortofon test record #0001, rumble spectra were recorded after first establishing a 0 dB reference at 5 cm/sec peak using Band 3. A General Radio 1564-A sound and vibration analyzer was set to its "all pass" mode and its gain controls were adjusted for a 0 dB reading on its meter. Then the offset on the X-Y plotter was set such that 0 dB on the wave analyzer corresponded to the major division marking, 1 inch below the top of the graph paper. Rumble spectra were recorded by playing the quiet grooves on Band 4 through the wave analyzer while sweeping it manually from 2.5 to 250 Hz over the space of about 1 minute. The sound and vibration analyzer was operating in its "narrow" (1/10 octave) mode. A gain of 20 dB was added using the stepped gain control to keep the signal at a suitable level (For exceptionally good turntable combinations 30 dB was required; for especially bad combinations only 10 dB was used.)

Acoustic and Mechanical Isolation

The acoustic isolation test was conducted by subjecting the turntable to a sound field whose intensity was 95 dB SPL overall at the turntable spindle. The sound field was produced with an Ivie Model 17A pink noise generator feeding a Marantz Model 15 power amplifier, which drove the woofer of an AR-3a. The loudspeaker was mounted on a separate support from the turntable to ensure mechanical isolation, and was located about 18 inches from the turntable. The frequency response of the sound field was checked at the turntable spindle with an Ivie Model 30A one-third-octave spectrum analyzer. It was flat within ± 3 dB from 40 to 250 Hz without equalization.

The acoustical isolation test was carried out immediately after the rumble test using the same equipment and without changing any of the gain controls except the stepped attenuator on the wave analyzer which was boosted an additional 20 dB. With the stylus resting on a stationary disc and the dust cover (if available) closed, the acoustic isolation spectra were recorded by manually sweeping the wave analyzer, just as in the rumble test.

The mechanical isolation test procedure was identical to that for acoustic isolation, except that the loudspeaker was switched off and the shaker table, on which the turntable was resting during the previous two tests, was turned on. The shaker table was constructed by bolting four inexpensive 10-inch speakers to a sheet of galvanized steel (24" x 24", 1/8" thick). This sheet was supported on rubber grommets held in place by screws resting on the lip of a wooden box (24" x 24", 6" deep).

To calibrate the shaker table, the frequency response was measured at several locations on its surface and under various load conditions (0 to 50 pounds). To measure the excitation levels, a phono cartridge was mounted on a steel rod attached to a mechanism (a milling vise mounted on a 50-pound cast iron base) which allowed the stylus to be lowered so as to contact the surface of the table with normal cantilever deflection. These tests showed that the shaker table had essentially no output below 20 Hz, but was ± 10 dB from 20 Hz to 250 Hz. It had significant mechanical impedance; i.e., its output amplitude dropped significantly as the load resting upon it increased. Thus the results of the mechanical isolation test cannot be used quantitatively. Rather we simply make rough comparisons of the relative performance of the various turntables tested..

Results

Horizontal Resonance

The graphs of horizontal resonance are shown in Figure 4. The first thing to notice is that there is an error in the test record. The record contains a 1 kHz test tone which is allegedly cut at the same level as the low frequency sweep. Ordinarily it would be impossible to check the level of the sweep relative to the test tone, because the sweep covers frequencies where the arm/cartridge combination is resonating and where the response is therefore elevated; in fact the degree of elevation is what we are trying to measure. We were fortunate in this case, however, to have two samples whose resonant frequencies are so low that the response has flattened out by the time the upper limit of 20 Hz is reached. These are samples 17 and 18, and from them we can see that the low frequency sweep has been recorded 1.5 dB too high. (It may be, of course, that the frequency response of the sweep isn't flat, either, but since we have no way of checking

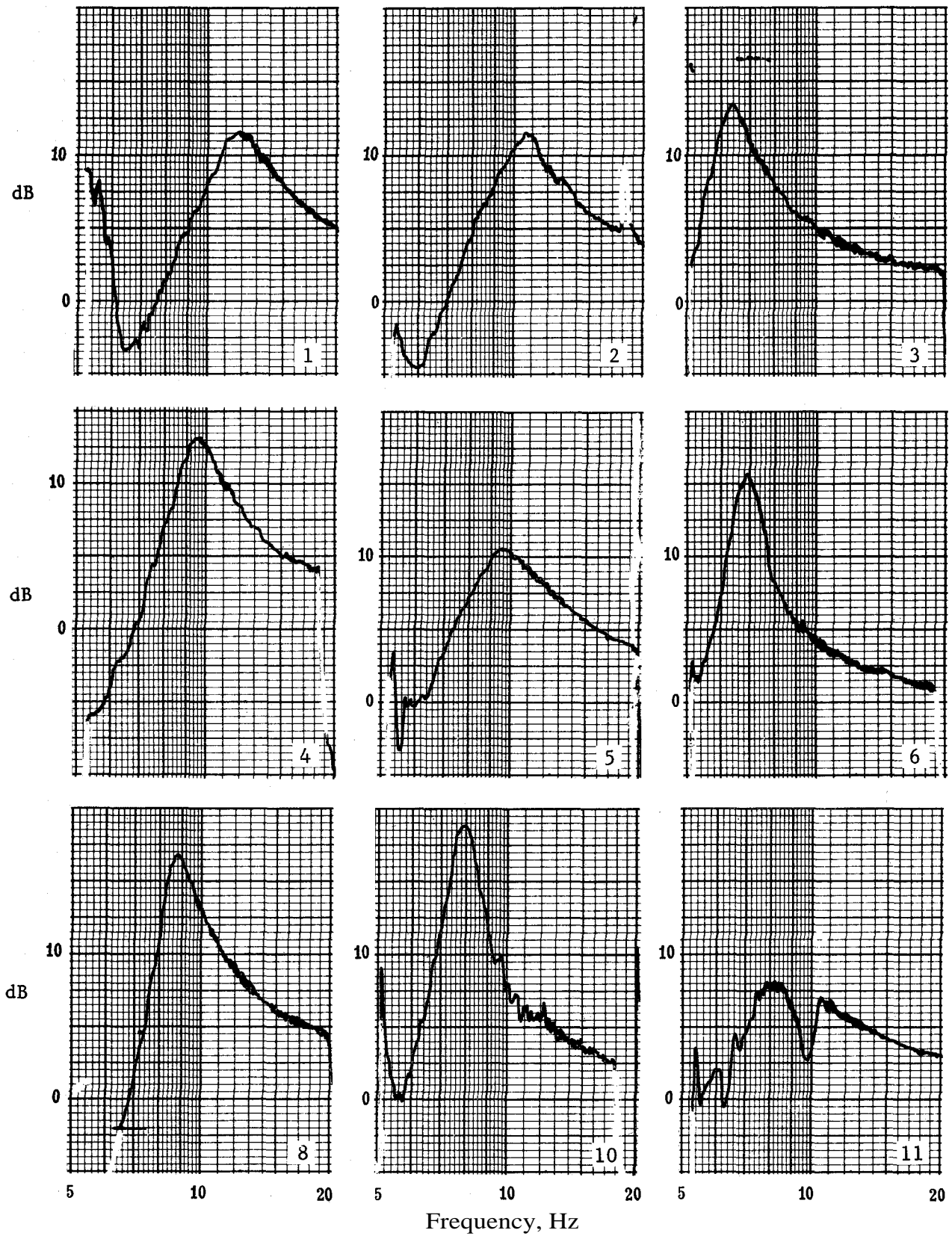

Fig. 4. Horizontal resonance

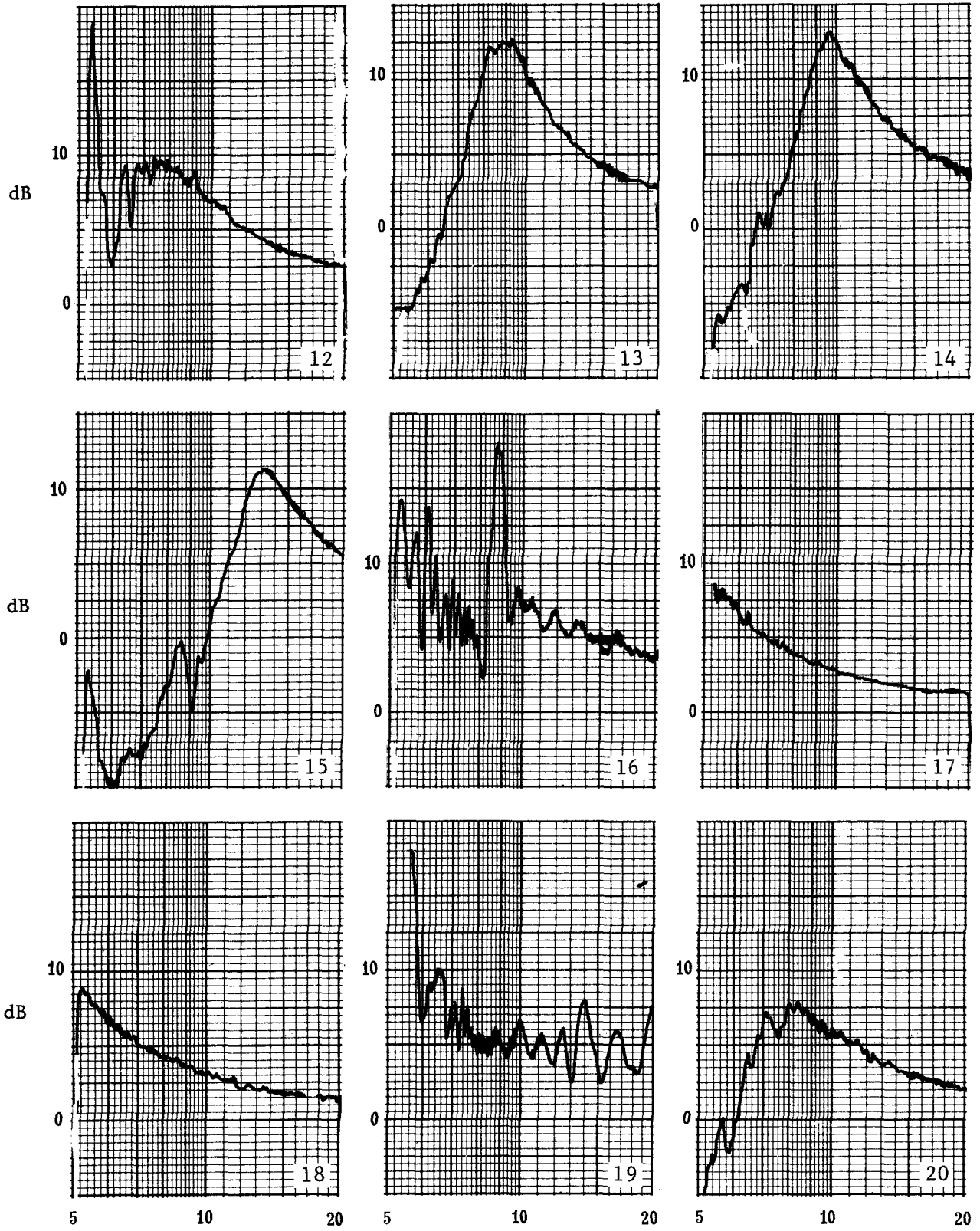

Fig. 4. Horizontal resonance (cont.)

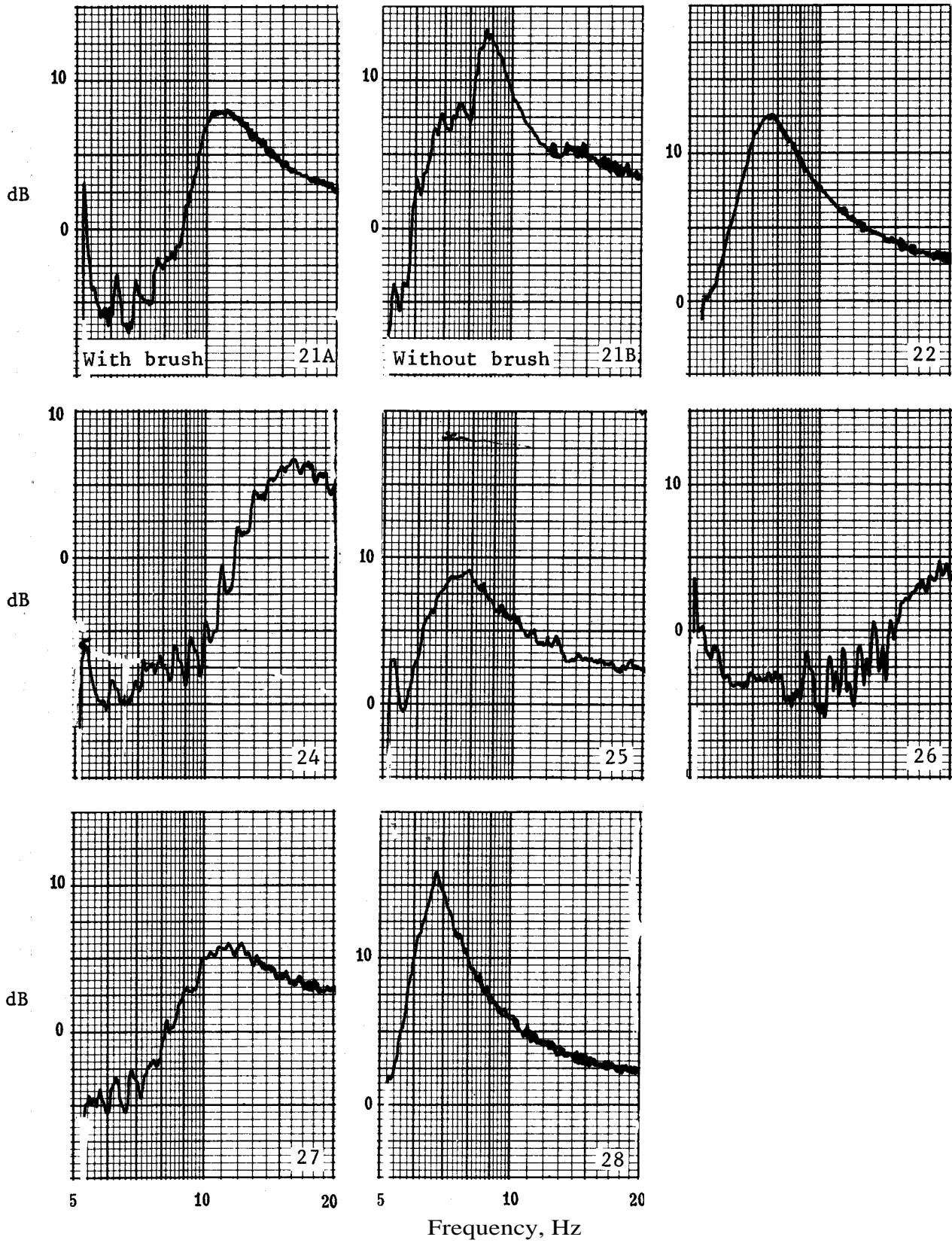

Fig. 4. Horizontal resonance (cont.)

that, we might as well assume that the problem is a simple level shift.) The effect of this error is that the resonances all appear to be 1.5 dB higher than they really are, so the appropriate correction has been made to the figures in Table 3, Column 3. When looking at the graphs, the traces should be shifted downward a distance of three small divisions.

Specific features of the graphs will be discussed in the "Comments" section at the end of the report. The results show a wide range both of frequency and of amplitude; the former ranges from below 5 Hz (samples 16, 17, 18, and 19) to above 20 Hz (sample 26), and the latter from 4 dB (sample 27) to just over 17 dB (sample 10).

Further comments by Al Foster: My own objective and subjective tests indicate that the amplitude of the resonance should be around 6 dB. If it is less than that, the system is overdamped. This condition is indicated by a rolloff below resonance which is more gradual than the ideal 12 dB/octave, thereby increasing the output of the system in the warp signal region, and by the spread of the upper part of the resonance into the audible range. One visible result is excessive stylus deflection on warped or eccentric records. If the resonance is higher than 6 dB, it makes the system overly sensitive to acoustical and mechanical excitation, interferes with the cartridge's ability to track, and will most likely produce audible sidebands. This is demonstrated in the B & K paper, wherein they played a 3 kHz pure tone and measured tone arm resonance sidebands only 5 dB below the 3 kHz tone. (This datum must be regarded as suspect, in my opinion. On Page 13 of the same paper there is another test of a system with identical resonant characteristics (+9 dB @ 7 Hz) which shows the sidebands 25 dB down. -- EBM) If the resonance is above 15 Hz, the low frequency output in the 20 to 100 Hz region will be raised.

Rumble

The rumble data could have been subtitled, "Variations on a Theme." Virtually all the plots had the same basic shape: a large peak at the tone arm/cartridge resonance, with output falling off very rapidly below, and more gradually above, that frequency. The peak had a maximum of -20 to -30 dB re the reference level of 5 cm/sec (peak) for the average units; the few that fell outside this range were marked above or below average. If -20 dB seems high, remember that the weighting curves commonly used to measure the rumble have very large attenuations at infrasonic frequencies. The DIN B curve peaks at 300 Hz, rolling off at 12 dB/octave both above and below that frequency; at 20 Hz it is -43 dB, at 10 Hz -55 dB. Unweighted rumble varies much more than weighted measurements because most of the "signal," i.e., the irregularities in the discs used for the test, fall between 4 and 7 Hz. If the tone arm resonance is down in this region, the unweighted rumble will be higher, perhaps by 10 dB or more. Some units showed peaks in their rumble spectrum coinciding with a resonance in the suspension of the turntable.

Above the low-frequency peak the typical spectrum rolled off gradually and steadily to about -45 dB at 20 Hz, and -50 dB or better at 50 Hz. The kind of audible rumble that one used to hear in misdesigned turntables and changers, which appears as one or more peaks of -40 dB or higher at 25 Hz or above, seems to be a thing of the past. On almost all the turntables, the output in the audible range was simply a measurement of the noise of the record surface, which at low audible frequencies is caused by what is known as mold grain.

Acoustical Isolation

The acoustical isolation curves, unlike the rumble curves, showed considerable variation in both shape and overall level. We divided the results into three categories -- below average, average, and above average -- by drawing a line on the graphs at -50 dB re 5 cm/sec peak at 1 kHz and seeing how the curve was placed relative to the line. The best units were 10 to 20 dB below the line almost everywhere, with peaks reaching almost up to the line. The average units were mostly below -50 dB, but rose as high as about -40 dB at one or more frequencies. The units we rated "below average" were above -50 dB for a major portion of the frequency range, sometimes reaching as high as -30 dB. We tended to allow a greater amount of breakthrough at the very lowest frequencies before we downrated a unit, on the grounds that the system can tolerate a greater level of interference below the audible range. Even the worst acoustic breakthrough did not produce as much signal at infrasonic frequencies as the rumble measurements, whereas some units did show more output from acoustical excitation than from rumble above 50 Hz. Some of

the curves were ascending when the 250 Hz measuring limit was reached; it would have been interesting in some cases to have carried the measurement a little higher.

The actual amount of acoustic breakthrough you experience at home is very heavily dependent on the physical set-up of your system and the acoustical and physical properties of your listening room. In general, most of these units would show no audible effects of acoustic feedback in most rooms while orchestral music is being played at realistic concert-hall levels. There might be problems with the worse ones if they are mounted in a poor location or if disco sound levels are being generated.

While the peak in the rumble data tended quite strongly to occur at the arm/cartridge resonance, the acoustic breakthrough data did not necessarily follow that pattern. On some plots the level rises at the resonance, while on others there is little infrasonic garbage at the arm/cartridge resonance but a big peak at a lower frequency. These peaks are most likely the result of resonances in the turntable suspension system. Performance in the audible range was highly variable. The best turntables were from -70 to -55 dB down between 20 and 250 Hz; the worst rarely went below -50 dB, and reached levels of about -30 dB.

Mechanical Isolation

The mechanical isolation curves are problematic in a way that the acoustical ones are not. The shaker table used had a high mechanical impedance; its excursion decreased as mass was added on top of it. To measure the isolation correctly, a consistent level of excitation is needed. Now, to some extent this situation is a duplicate of many real-world installations; sometimes a heavy turntable will help a vibration problem by clamping down the shelf or table on which it is resting. But any predictions about performance in the home are risky, as they are in the case of the acoustical measurements, and for the same reason. Because of the shaker table problem, we would expect the heavier tables to perform better on this test. Although we didn't actually weigh the units, we found a wide variation in mechanical isolation (so far as we could read it) which was not strongly correlated with turntable mass.

It was interesting to notice the extent to which the acoustical and mechanical breakthrough curves took the same shape for a given unit. We have rated the units, on a tentative basis because of uncertainties in the measurement discussed above, in the same manner as we did the acoustical breakthrough, only with a reference line of -40 dB instead of -50. The shaker table was undergoing some rather violent excursions (approximately 1/8 inch peak-to-peak), far greater than would be encountered in any normal home playback situation. The "average" units were the ones whose curves rose above -40 dB only occasionally; the "below average" curve was above -40 for a substantial portion of its range, with occasional peaks of -30 dB or so.

Comments on the Individual Units

1. The horizontal resonance at 12 Hz shows up in the rumble curve, but not in the isolation tests. The Linn is widely regarded as especially resistant to acoustic and mechanical feedback, but this unit exhibits a 20 dB peak at 5.5 Hz in its isolation curves which kept it out of the "above average" category. This peak, which also shows up in the horizontal resonance curve in Figure 4-1, can (and sometimes does, in our experience) cause problems in the wrong installation. It is almost certainly the product of a resonance in the suspension of the turntable.

There is a peak in the mechanical isolation curve at 80 Hz which rises from the surrounding area (which is -55 dB down) to only -35 dB. This corresponds to a glitch in the frequency response (see Figure 1-1 in the previous issue). All the Formula IV arms had this problem, as did the Thorens TD-166 in sample 11 and the Grace 707 in sample 10, although at varying frequencies and with varying amounts of effect on the isolation performance. The extent to which these things are audible is unclear, but they do point to a common problem, which is that it is difficult to design an arm with both very low mass and sufficient rigidity.

2. The arm/cartridge resonance at 11 Hz is visible in all the other curves. But what put this unit in the "below average" group in the isolation tests was mechanical breakthrough at 30 Hz and mechanical and acoustical breakthrough at 80 and 200 Hz. Some, but probably not all, of the 80 Hz problem comes from the Formula IV.

Table 3

Sample	Horizontal Resonance		Isolation			DIN Weighted Flutter, peak (%)	Spindle Diameter (.001")
	Freq. (Hz)	Ampl. (dB)	Rumble	Acoust.	Mech.		
1	12	10	+		=	0.12	280
2	11	10				0.13	282
3	6.4	12			=	0.07	281.5
4	9.5	11.5	+		=	0.06	282.5
5	9.5	9		+	+	0.05	NA
6	7	14	=	=		0.10	283
7	NA	NA	NA	NA	NA	0.07	284
8	8.8	15	=			0.044	281
9	NA	NA	NA	NA	NA	0.07	281
10	8	17	=	-	=	0.09	281.5
11	8	6	=		NA	0.06	282
12	7.5	8	=	-	=	0.065	NA
13	9	11	=	-		0.11	NA
14	9.6	11.5	+	-		0.13	284
15	13	10	+	-	=	0.11	281
16	<5	NA	=	+	+	0.10	284
17	<5	NA	+		=	0.07	282
18		NA	=	-	=	0.07	281
19	<5	NA	=	NA	NA	0.17	284
20	8	6	+		=	0.08	NA
21	11/8.8	6.5/11.5*	+	+	+	0.07	284
22	7.6	11	=	+	+	0.08	281
23	NA	NA	NA	NA	NA	0.08	276
24	16	5	=	+	+	0.09	284
25	7.5	7.5	=			0.075	276
26	>20	NA	NA	+	+	NA	NA
27	11.5	9	+	-	+	0.12	283
28	6.8	14.5	=	+	+	0.12	282

* With/without brush, + Better than average, = Average, - Worse than average

3. A 20 dB peak in the rumble curve corresponds with an arm/cartridge resonance at 6.5 Hz, down in the warp region. Acoustical and mechanical isolation are good at infrasonic frequencies, but only fair in the audible range.
4. The rumble of this combination was better than average despite the 11.5 dB resonance at 9.5 Hz. Isolation was good at infrasonic frequencies but only fair up higher, with the maximum at 100 Hz in both curves.
5. This turntable, a Kenwood KD-500, had been extensively reworked. Large amounts of Duxseal and lead were added to the original base, and the whole thing was mounted on a one-inch thick wad of Duxseal resting on a piece of 3/4-inch plywood, which was suspended on upholstery springs. The resulting assembly weighs slightly over 80 pounds. The purpose of the whole exercise was to reduce acoustic and mechanical breakthrough, and the results were visible in both curves. There is still a resonance at 6 Hz in the system somewhere, but the curve reaches only -50 dB in both tests. The portion from 10 to 50 Hz is outstanding, being -70 to -75 dB on both curves. Between 50 and 250 Hz the results are somewhat less good, but still below -50 dB almost everywhere. The turntable to beat in these tests is the AR, which arrives at a similarly low resonant frequency in its suspension through the use of low mass and very soft springs. This sample is better than the ARs below 50 Hz and not quite as good above; if we had to award a first prize for resistance to external disturbances this unit would win by a small margin.
6. The horizontal resonance of the arm/cartridge is a very sharp peak, reaching +14 dB at 7 Hz. (Unlike many earlier moving coil cartridges, the 103D is quite compliant.) This resonance appears in all three plots. Isolation in the rest of the frequency region is only fair, so the unit was downrated. However, the owner of this sample also owns a Linn, and in certain locations in his listening room the Linn has feedback problems and the Braun does not. This is another example of the degree to which the variability of individual circumstances can destroy the predictive abilities of tests such as these.
8. The severe arm/cartridge resonance, +15 dB at 9 Hz, is visible in the rumble test- but not significantly in the isolation tests. The acoustical isolation has no high peaks but is worse than -50 dB much of the time. The mechanical isolation shows peaks at 30 and 120 Hz.
10. The undamped Grado in the undamped Grace 707 has the highest resonance we measured, +17 dB at 8 Hz. While this peak shows up in the other three curves, the overall performance in each category is otherwise quite good, hence the average rating.
11. Thorens uses a rubber-decoupled counterweight to damp the arm resonance. The effect of this is visible as a dip at just under 10 Hz in Figure 4-11. The curve shows excellent damping elsewhere too, because the NAD cartridge is internally damped; this unit is tied for second place with sample 20 in this department. Mechanical isolation data is not available for this sample, but the acoustical test shows a very pronounced peak at 5 to 6 Hz, the result of an undamped resonance in the turntable suspension, that cost it its average rating.
12. Another Thorens turntable suspension resonance; this one is visible in Figure 4-12. The unit was otherwise good; for some reason the Formula IV glitch at 70 Hz (Figure 1-12) does not show up in the isolation tests.
13. The ST-7 has some acoustic and mechanical breakthrough at 30 Hz and from 50 to 100 Hz.
14. The Empire has better than average rumble despite a fairly high arm/cartridge resonance. The isolation tests, however, showed problems in a broad area from 70 to 200 Hz.
15. Another Linn, also with a 6 Hz suspension resonance, but this one is not as severe as in sample 1. Isolation tests were good, and rumble is better than average.
16. This AR turntable is quite old, and may be having friction problems in its tone arm. The sharp peak at 9 Hz is not a normal resonance, but may be a sign of something loose in the cartridge mount or the arm. The response in Figure 4-16 is still rising at 5 Hz, and the other curves show peaks at that frequency. The cartridge, a Shure V-15 Type II, may be adding to the

problem somehow; it is very old. The AR turntable turned in above-average performances in the isolation tests despite the low frequency peak.

17. Another Shure, this one a Type III, with an extremely low-frequency arm/cartridge resonance. For some reason, the other curves do not seem to match each other well; the rumble is better than average, the acoustical isolation is worse, with a big peak at 10 Hz and another at 50 Hz, and the mechanical isolation is average. The Discraker, which was in use during the tests, may have had something to do with these results, but exactly what isn't clear.

18. Another Shure Type III, another extra-low resonance. The rumble curve has a peak at 6 Hz, suggesting that the vertical compliance of the Type III may be less than the horizontal.

19. Another low-frequency resonance, this one with a rough-looking curve similar to sample 16. Isolation data are unavailable for this unit; rumble was average, with the same sharp peak at 5.5 Hz whose right-hand half is visible in Figure 4-19.

20. If you haven't already noticed, the samples in this project are arranged by cartridge make and model; this is a Shure Type IVG, which is a Type IV with a conical stylus. The brush was used for this test, which shows a very well-damped resonance at 8 Hz. Rumble was better than average, and in fact looks rather like the curve in sample 17, where a Type III was used with a Discraker, although sample 17's rumble curve was even better. Interestingly enough, both 17 and this one have lots of acoustic breakthrough at infrasonic frequencies, although sample 17 has a fairly narrow peak at 10 Hz and this one has output everywhere from 5 to 12 Hz. The mechanical isolation is only fair up to 25 Hz, and good above that. Neither isolation curve is as good as the other AR turntables, though, because the custom-mounted Rabco arm mechanically shorts out the turntable suspension.

21. Here we see what the Shure brush does for the horizontal resonance. Without the brush (21B) the curve is peaky and rather odd-shaped, reaching +16.5 dB at just under 9 Hz. With the brush (21A) the frequency moves to 11 Hz and the amplitude down to 6.5 Hz, just about ideal. This tone arm is a custom design by Bob Graham, similar to the model which will be marketed soon by McIntosh. This arm is suitably rigid, but quite light, hence the higher resonant frequency than the Type IV with brush in sample 20. The turntable is a modified AR, and like the stock versions shows a peak in the rumble and isolation tests at about 5 Hz, with performance excellent elsewhere. Both acoustical and mechanical isolation showed some sign of worsening at 250 Hz, but since the measurements stopped there, the extent of the problem, if any, could not be determined.

22. Average horizontal resonance, a peak in the rumble data from 7 to 9 Hz, better than average isolation, especially at low frequencies, although some deterioration above 150 Hz is evident. Japanese turntables are as a rule more stiffly sprung than some others, such as Philips, AR, and Thorens, and so do not show the same low frequency peaks. Oddly enough, some, like this one, do not have problems in the 20 to 50 Hz range either.

24. A very odd resonance, at a very high frequency (16 Hz) considering the Sonus Blue Label cartridge, which is supposed to be extremely compliant. This cartridge is about two years old, and has been tracked for most of its life at 1.6 grams. It is possible that the cantilever suspension material has stiffened with age and use. The rumble and isolation curves all show a large peak at 5 Hz, larger than the other ARs. This may be because the stock turntable mat has been replaced with a Disk-SE22 mat that weighs about two pounds. This necessitated tightening the suspension springs to refloat the platter/arm subassembly, which had bottomed out. The final result was a system with the same resonant frequency as before, but with higher mass, and consequently lower damping. In this instance it looks as though the mat has made things slightly worse (no audible difference was observed at the time of the switch). Aside from the 5 Hz peak the isolation curves are excellent.

25. Well-controlled horizontal resonance, adequate rumble performance, but distinctly inferior acoustical and mechanical isolation, with a broad problem area in the acoustic data from 10 to 30 Hz, and a peak at 80 Hz that may be another Formula IV glitch. Mechanical breakthrough at 20 to 23 Hz, 80 Hz, and 170 Hz.

26. A moderately compliant cartridge in an extremely light straight-line tracking arm yields the highest resonance in the bunch, which judging by the isolation tests is around 27 Hz. Rumble data not available, isolation tests both better than average by a small amount.

27. A Stanton 681EEE in a stock Philips 212 yields the best-damped resonance in the bunch, +4 dB at 11.5 Hz. Some would argue that this is too much damping; the frequency response in Figure 1-27 does rise a teeny bit at the very bottom. Rumble is very good; acoustic isolation is mediocre below 20 Hz, good above. Mechanical isolation is better than average.

28. Another Stanton cartridge, in a heavier arm. There seems to be quite a bit less damping in the 881S than in the 681EEE; the resonance is +14 dB. Isolation (both kinds) was better than average across the spectrum. Kenwood's claim about concrete providing natural damping should be taken with a pinch of salt, but the turntable as a whole seems to have achieved its design goal of, good isolation.

The BAS Constitution. Revisited

The Constitution Revision Committee--Dave Bredemeier, Frank Farlow (Ch.), Larry Kaufman, Peter Mitchell and Jim Thoroman--are happy to present to you the fruit of their labor. In fashioning this proposal our main intentions have been to bring the constitution and by-laws into line with current realities and practice (this is their first general overhaul in eight years), and to generally consider the current provisions with a jaundiced eye in hope of discovering and rectifying a few of their deficiencies. We have also tried to reorganize and rationalize the documents to render them more comprehensible to new readers and more quickly usable by the members who must periodically refer to them to check specific provisions.

We're photoreducing the proposed amendments on the assumption that those of you who are interested in this type of fare are likely to be sharp-eyed anyway, and in order to keep dues down. We're not including a copy of the current constitution both because of printing and postage costs and because copies remain available via the membership application form for those who want one.

Following is a summary of the primary changes proposed:

1. The by-law articles are reshuffled such that the subjects of Articles III-VIII bear the same numbers as their counterparts in the constitution. (Articles I and II have no subject counterparts.)
2. The editor of the Speaker is made an officer, although still appointed by the Executive Committee, and an ex officio member of the Executive Committee.
3. Also added to the Executive Committee, as its first nonvoting members, are the chairpersons of temporary committees. (The other members are the four elected officers and the chairpersons of standing committees.)
4. The treasurer's responsibilities are increased for reporting to the membership concerning the financial condition of the BAS and how its monies are being spent.
5. Limitations are placed on the tenure in office of officers and committee chairpersons.
6. Reimbursement in full is provided for members who incur expenses on behalf of the BAS.
7. The formula for determining compensation of officers and other hard working members is changed. Currently the by-laws provide that each elected officer shall receive a maximum of \$1 per member annually. Current practice is that 67c per member is paid to each officer and to the editor, and another 67c is divided among various other members, most of whom are associated in one way or another with production of the Speaker. Read the new proposal in full in Article IV, Sections 3 and 4 of the by-laws.
8. The titles and job descriptions of the officers are brought into correspondence with current practice.

There will probably also be some interest in the primary changes considered but not proposed:

1. Two years ago the quorum for general meetings was redefined as two thirds of the average meeting attendance during the first three meetings of the membership year. No change is proposed in this formulation. Also, we decided not to propose that a quorum be generally required for the conduct of business at general meetings, but to support retention of the current practice of requiring a quorum only for specific types of actions.
2. Despite the fact that some tense moments have been spent over this issue at several meetings in recent years, we decided not to recommend significant changes with respect to the question of whether the course of events within the BAS should continue to be controlled almost exclusively by the local membership (i.e., those who attend meetings). Thus, if our recommendations are accepted it will remain the case that all references to the process of direct decision-making involve actions taken by the Executive Committee that are reviewable by the members in attendance at general meetings, or actions taken by those members themselves. Also, although members not able to attend the Annual General Meeting can participate in the election process by sending in signed ballots, there are no provisions requiring the encouragement of this process, e.g., by sending printed ballots to all members.

Finally, we consider it important that all members interested participate in the modifying and finalizing of these proposed amendments so that the current constitution and by-laws can be amended by substituting the new documents in their entirety. To expedite this process, I encourage those of you who will not be able to participate in the process of dissecting the proposals at our monthly meetings to contact me directly with your observations and recommendations at 8 Bowker Street, Brookline, MA 02146 (617-232-9654 day or night). If your comments should reach me after our proposals have been acted upon locally, they will be presented to the Executive Committee on an ongoing basis for further consideration.

-- Frank Farlow (Massachusetts)

CONSTITUTION
of the Boston Audio Society

ARTICLE I: Name

The name of this organization shall be the Boston Audio Society, abbreviated BAS hereafter.

ARTICLE II: Objectives

The BAS has been formed to bring together people with a common interest in hearing music reproduced at its best, for their mutual edification and pleasure; to facilitate the exchange and dissemination of accurate information concerning audio equipment and recordings of music; to promote, sponsor, and cultivate the highest quality reproduction of music in the home; to encourage maintenance of high standards in the performance, recording, and transmission of music; and to support the identification and application of relatively inexpensive techniques for achieving high quality music reproduction, in order to increase the rate at which significant developments and improvements in "state of the art" audio products and services become accessible to the general, non-audiophile public.

The Society shall pursue these objectives by providing a forum for meeting other audiophiles and exchanging information concerning audio equipment and recordings of music; by demonstrating and comparing such equipment and recordings; by giving its members opportunities to become familiar with the techniques of audio manufacturing, testing, repair, recording, broadcasting, etc.; and by such other means as the membership may consider appropriate.

Reports of evaluations and tests carried out by members of the Boston Audio Society or its committees shall be for the information of the membership, and shall represent solely the views of their authors. The Society shall not, as a body, either endorse or criticize any product, service, dealer or manufacturer, and it shall actively discourage, deny, disclaim, and dispute any such action.

ARTICLE III: Membership and Dues

Any person sharing the common interests of the members of this Society as set forth in Article II may become a member upon payment of dues to the treasurer.

ARTICLE IV: Officers

The BAS shall have four elected officers: a president, a corresponding secretary, a membership secretary, and a treasurer. A fifth officer, the editor of the Society's periodical, shall be appointed by the Executive Committee. Officers must be dues-paying members of the Society, and they may act as etc officio members of all committees.

ARTICLE V: Executive Committee

Management of the affairs of the Society shall be carried out by an Executive Committee consisting of the elected officers, the editor of the Society's periodical, and the chairpersons of standing committees of the Society. Chairpersons of temporary committees shall be nonvoting members of the Executive Committee.

The Executive Committee shall have sole power to interpret the Constitution and By-laws and to decide upon matters not provided for therein. At each general meeting, the presiding officer shall report the actions and decisions taken by the Executive Committee

since the previous general meeting. If the members in attendance feel that any action reported is not in the best interests of the Society, they may reject it by a three-quarters majority vote. The Executive Committee shall have the right to participate in such a vote as individual members.

ARTICLE VI: Meetings

Although general meetings shall normally be held on a monthly basis, a general meeting of the BAS held in September shall be called the Annual General Meeting. If this meeting is canceled due to inclement weather or other factors beyond the Society's control, it shall be held at the earliest practical date thereafter.

ARTICLE VII: Committees

The Executive Committee shall have the power to establish standing and temporary committees to assist in fulfilling the objectives of the Society.

ARTICLE VIII: Amendment

This Constitution may be amended by consent of three quarters of the members present at any general meeting attended by a quorum consisting of two thirds of the average number of members attending the first three general meetings in the current membership year. (Until these three meetings have taken place in a given membership year, the previous year's quorum shall obtain.) Proposed amendments shall first be presented to the membership at a general meeting and mailed to members not later than five weeks thereafter, together with recommendations of the Executive Committee and other interested members. Voting shall then occur at the next general meeting attended by a quorum.

BY - LAWS

ARTICLE I: Fiscal Matters

Section 1: Fiscal Year

The Society's fiscal year shall be October 1 through September 30. The treasurer's records shall be audited by the Executive Committee at the end of each fiscal year.

Section 2: Expenditure of Funds

The Executive Committee shall be responsible for the expenditure of the Society's funds, consistent with the purposes of the Society as outlined in Article U of the Constitution. Payments may be authorized, for example, to individuals or organizations for services rendered, as honoraria for speakers, and as reimbursement for expenses incurred on behalf of the Society.

Section 3: Officers' Honoraria

At the end of each fiscal year each officer of the BAS shall receive from the treasury an honorarium of \$100 in recognition of his or her services to the Society.

Section 4: Compensation of Members for Clerical Work

At the end of each fiscal year, officers and other members who have contributed sub,

stantial amounts of time and labor to the routine work of the BAS shall receive from the treasury token compensation in recognition of their services to the Society. The total of such compensation shall not exceed \$4 multiplied by the number of members at the end of the fiscal year, and the total amount received for a given fiscal year by any officer under provisions of this and the preceding Section (i.e., honorarium plus clerical work compensation) shall not exceed \$800. The distribution formula for clerical work compensation shall be determined by the Executive Committee, primarily on the basis of time contributed to the work of the Society.

Section 5: Reimbursement of Expenses Incurred

Expenses legitimately incurred by members acting on behalf of the Society shall be reimbursed in full.

Section 6: Attendance Fees

There shall be no attendance fee for most meetings. However, if the Executive Committee foresees the need of income to offset the cost of a special program, lecture, demonstration, or other expense judged to be in the best interests of the membership, such a fee may be required. In this event the membership shall be advised of the fee when the event is announced.

ARTICLE R: Publications

The Society shall issue, to the extent possible on a monthly basis, a publication entitled the BAS Speaker, which shall contain technical articles and other information of interest to the membership and reports concerning the various activities of the BAS. A disclaimer embodying the intent of Article II, paragraph 3 of the Constitution shall be included prominently in each issue of the Speaker.

ARTICLE III: Membership

Section 1: Membership Year

The membership year shall be October 1 through September 30.

Section 2: Rights of Members

In the absence of decisions by the Executive Committee or the membership to the contrary concerning particular events, payment of dues shall entitle a member's immediate family to participate in all of the Society's nonvoting activities.

Section 3: Honorary Membership

Persons deemed by the membership to have contributed extensively to the well-being of the BAS may be elected to honorary life membership by simple majority vote of the members in attendance at any general meeting.

Section 4: Expulsion of Members

The Executive Committee, acting on behalf or at the behest of the membership, shall have the power to recommend expulsion from the Society of a member deemed to have excessively abused the rights of membership. Persistent misrepresentation of the member's connection with the Society for personal gain, or actions showing flagrant disregard

for the provisions of Article II, paragraph 3 of the Constitution are examples of conduct that might be considered grounds for expulsion. A two-thirds majority vote of the members in attendance at any general meeting shall be required for expulsion.

ARTICLE IV: Officers

Section 1: Duties

President. The president shall preside at general meetings, and call and preside at meetings of the Executive Committee (if in either case the president is unable to preside, the attending elected officers shall select one of their number to preside); act as the Society's spokesperson; be responsible for recording the actions and decisions of the Executive Committee; and report such actions and decisions at each general meeting.

Corresponding Secretary and Membership Secretary. During each term of office, division of the following responsibilities between the offices of Corresponding secretary and membership secretary shall be proposed by the two incumbents for approval by the Executive Committee: conducting and maintaining records of the general correspondence of the BAS; responding to all inquiries and processing applications for membership; preparing and mailing announcements of meetings, elections, and proposed amendments of the Constitution and By-laws; maintaining a record file of back issues of the BAS Speaker; and filling members' orders for back issues of the Speaker.

Treasurer. The treasurer shall collect membership dues; manage the Society's funds in a manner approved by the Executive Committee; maintain the Society's financial records; disburse funds as authorized by the Executive Committee; make recommendations to the Executive Committee and subsequently to the membership at a general meeting concerning the setting of dues; and provide in addition not less than one comprehensive report annually to the membership concerning the financial condition of the BAS and the purposes for which its monies are being expended.

Editor. The editor of the BAS Speaker shall be responsible for recording the activities of general meetings and prepare a report of each meeting for publication in the Speaker, and shall edit the Speaker and supervise its publication.

In addition to carrying out the duties prescribed above, the officers, acting as members of the Executive Committee, shall be responsible for the general governance of the Society's affairs.

Section 2: Election to Office

The elective offices shall be filled at the Annual General Meeting provided a quorum is present; if a quorum is lacking, the incumbent officers shall continue in office until the conclusion of the next general meeting at which a quorum is present and an election is therefore held.

Nominations shall be accepted from the floor at the preceding general meeting, and at least ten days before the Annual General Meeting an election announcement shall be mailed to members identifying the nominees and containing optional brief position statements (not exceeding 200 words) by the candidates for office. Additional nominations shall be accepted at the Annual General Meeting prior to balloting.

Election shall be by simple majority of the members in attendance. Members not in attendance may vote by signed ballots postmarked prior to the Annual General Meeting and received not more than twenty days after the meeting. If no candidate for a given office receives a majority of the votes cast, a run-off election shall be held between the two leading candidates.

Section 3: Terms of Office

Terms of the elective offices shall be October 1 through September 30, coinciding with the membership year and the fiscal year, with the exception that the treasurer's term shall be November 1 through October 30.

A member may serve no more than three consecutive terms in elective office, after which a period of at least one year shall elapse before that member may again hold office, with the exception that any officer other than the president may be elected president to serve for a subsequent maximum of three consecutive terms. The editor's tenure in office shall be limited to four consecutive years from date of appointment.

For elected officers incumbent at the time of adoption of this Section, the current term shall be considered the first of their three consecutive terms. (When the last of the elected officers incumbent at the time of adoption of this Section leaves office, this paragraph shall be deleted from the By-laws.)

Section 4: Removal from Office

The tenure of any officer may be terminated for failure to act in the Society's best interests. Any member may petition the Executive Committee to consider such a termination, and the Executive Committee shall meet to consider such a petition within one month. The officer in question shall be given fourteen days' notice of this meeting, at which he or she shall have the opportunity to respond to the petition. At the next general meeting of the Society attended by a quorum, the Executive Committee shall recommend for or against removal from office, the officer may speak in his or her defense, and members shall vote on the recommendation. The meeting announcement mailed to members shall include notice of this vote. A three-quarters majority of those voting shall be required to remove an incumbent from office.

Section 5: Vacancies

In the event that a vacancy occurs during a term of elective office, a special election shall be held within two months to fill the vacancy for the remainder of the term. A simple majority shall be required for election. However, if such a vacancy occurs within three months of the end of a term, it may be filled for the remainder of the term by Executive Committee appointment.

ARTICLE V: Executive Committee Quorum

For the conduct of business by the Executive Committee, a quorum consisting of a majority of its members, including at least three officers, shall be required.

ARTICLE VI: Meetings

Section 1: General Meetings

A general meeting shall normally be held on the third Sunday of each month. Notice

in writing of all general meetings shall be mailed to the local membership (Massachusetts residents, out-of-state members living within an hour's driving time, and other members requesting notification) at least one week in advance of the meeting date. This notice shall include a brief agenda of the forthcoming meeting.

Section 2: Special Meetings

In addition to general meetings, the BAS may undertake other activities as appropriate, such as field trips, test clinics, etc., which may be limited in number of attendees and/or to members only.

Section 3: Emergency Meetings

It shall be the right of any member to contact an elected officer of the Society to recommend a special meeting, either for reasons of special interest to the membership or in the event of an emergency. The Executive Committee shall weigh the merits of such a request and decide whether such a meeting is warranted. If so, the membership shall be advised by appropriate means and the meeting held as promptly as the occasion warrants.

Section 4: Quorum

When the word "quorum" is used in these By-laws, it shall bear the following meaning in the absence of provision to the contrary: two thirds of the average number of members attending the first three general meetings in the current membership year. (Until, these three meetings have occurred in a given membership year, the previous year's quorum shall obtain.) It shall be the membership secretary's responsibility to make the necessary counts.

Section 5: Procedure

Questions of procedure that arise at general meetings shall be decided by the presiding officer in accordance with Roberts' Rules of Order. These rules may be suspended, however, by a two-thirds majority vote of the members present.

ARTICLE VII: Committees

Committee chairpersons shall be appointed by the Executive Committee and shall serve in that capacity for a maximum of three consecutive years from date of appointment. Chairpersons of all committees shall be ex officio members of the Executive Committee, but only those of standing committees shall have voting privileges.

ARTICLE VIII: Amendment

Proposed amendments to these By-laws shall be presented to the membership in advance of the general meeting at which they are to be considered. By-laws may be amended with the consent of two thirds of the members present at any general meeting attended by a quorum.